



**Product guide**

Heating homes has  
never been easier

# Find the answer to your heating needs



## Comprehensive business support

With a range of tools to help you grow your business, Atlantic Heat is on hand to ensure you have the support you need.

We are available to take your calls Monday to Thursday 8.30am to 5pm and Friday 8am to 4.30pm.

Helpline: 0844 3350 549



## Complete design process

Electric heating can be installed in most domestic and light commercial applications, our comprehensive design service provides a full plan for architects and specifiers.



## Quick & easy

With Click & Go functionality, installation is fast and stress-free - perfect for when you're installing large quantities for major projects.



## Product reliability

Atlantic Heat products are founded on more than 40 years of heating innovation. You can be sure that each product delivers reliability as standard.

# Sokio

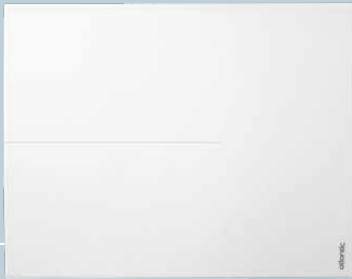

 Open window detection

 2 modes: Manual/Programmable



See more  
**P06**

# F127



 Open window detection

 2 modes: Manual/Programmable  
24 hour 7 day timer



See more  
**P08**

# Agilia



 Absence & Presence detection

 Open window detection



See more  
**P10**

# Accessio

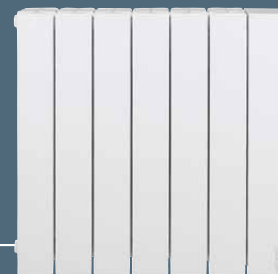

 Fitted with user-friendly digital controls driving energy savings

 6-command pilot wire: Comfort, Comfort -1°C, Comfort -2°C, Eco, Frost-free, Off



See more  
**P12**

# Galapagos



Tracks the user's requirements adapting heating accordingly

Switches heater to minimum when window is opened



See more  
**P14**

# Oniris



Absence & Presence detection

45% of radiant heating, faster warm up



See more  
**P18**

# LST HEATER



Easy prog: 24h/7, program your device according to your life rhythm for greater comfort and savings

Open window detection



See more  
**P22**

# Air Curtain



3 heat settings

Fan only setting for air circulation

\* Compared to a mechanical convector



See more  
**P24**

# Contents

As part of Groupe Atlantic, the Atlantic electric heating brand is synonymous with quality and efficiency.

We understand that you need a partner who has the skills and expertise to deliver a wide range of reliable heating solutions to suit your needs.

Developed with the installer and end user in mind, we combine premium design with cutting edge technology to bring you a wide range of easy-to-install and reliable heating systems.

Our products are founded on more than 40 years of electric heating innovation and with convector, radiant and connected heating solutions, there's an extensive range to suit everyone's requirements.

Atlantic Heat, experts in electric heating systems and home comfort appliances.



Scan to follow us on Instagram

1	Contents page	p03
2	Designed with you in mind	p04
3	Sokio	p06
4	F127	p08
5	Agilia IO	p10
6	Accessio	p12
7	Galapagos	p14
8	Oniris	p18
9	CozyTouch, IO Home Control & Smart Pilot	p20
10	LST Heater	p22
11	Air Curtain	p24
12	Sensis Towel Rail	p26
13	Atlantic Direct	p28
14	Why choose electric heating?	p30

# Designed with you in mind



**With a range of features including easy installation at second fix stage and energy efficient controls, all Atlantic electric heating products are designed with both the installer and end user in mind.**

For ultimate home comfort each product in the range comes with integral, easy to use heating controls, with some electric heaters even featuring energy saving smart technology which adapts heating depending on room occupancy.



## Designed with you in mind

- Quick and easy installation at second fix stage or later – ideal for new developments, renovation or refurbishment projects
- No annual service required
- Complete reliability with minimal moving parts
- Energy savings when compared with conventional heating
- 100% efficiency at the point of use
- Design freedom – electric heating can be installed virtually anywhere
- Highly accurate electric thermostats
- Innovative energy saving heating controls
- App based heating control option\*
- ErP (Lot20) compliance

\*Where applicable

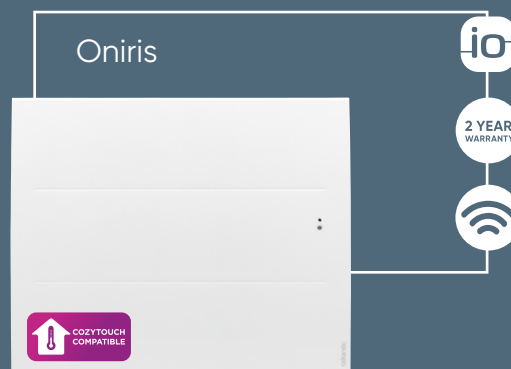

\*Where applicable

# Sokio

Electric radiator

2 YEAR  
WARRANTY



## Description

- 750 to 2000W
- LCD digital screen
- Asymmetric
- Colour: RAL9016 White



The Sokio electric radiator combines clean, asymmetric styling with aluminium plate technology giving you soft, homogeneous heat.

Sokio can be used in basic mode, which gives easy, flexible control to the user ensuring the heating is right for them. Alternatively use the Sokio in programmed mode for pre-set times and temperatures.





## Key features

-  Gentle, homogeneous heat
-  Integrated programming to adjust to the users life rhythm
-  Customizable programming
-  Open/closed window detection\*\* function switching to anti-frost mode as soon as a window opens
-  Ergonomic LCD digital controls showing temperature and energy consumption
-  2 modes: Manual/Programmed
-  Clean asymmetric design fits in with any room

## Dimensions

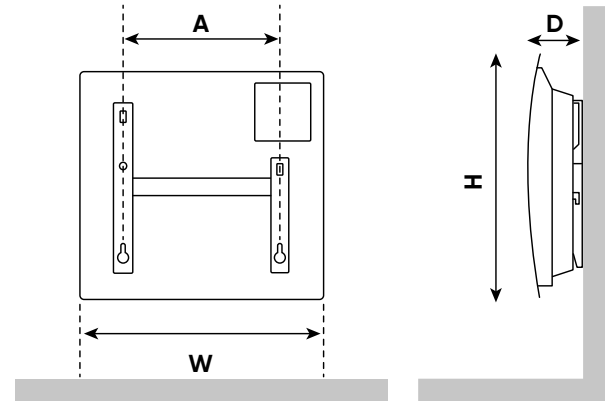

## Sokio technical data

OUTPUT (W)	DEPTH (MM)	WIDTH (MM)	HEIGHT (MM)	A (MM)	WEIGHT (KG)	CODE
750	130	601	477	343	8.3	AH503108
1000	130	601	477	343	8.3	AH503109
1250	130	823	477	565	10.1	AH503111
1500	130	823	477	565	10.1	AH503113
2000	130	1045	477	787	13.1	AH503114

# F127

Electric Panel convector

2 YEAR  
WARRANTY



## Description









- 500 to 2000 kW
- Built in energy saving features
- Manual or Programmed
- Open window detection
- Colour: RAL9016 White



The F127 is an active heat convector with easy to use controls that is suitable for a range of applications. The F127 allows 24 hour, 7 days a week programming to cover a multitude of situations. With its simple design and easy fixing it's perfect for anything from a single, to high volume installations.



## Key features

-  Open window detection
-  2 modes: Manual/Programmable 24 hour 7 day timer
-  High-precision electronic thermostat
-  Ergonomic LCD digital controls
-  Up to 25% energy savings\*
-  Sheathed heating element with an aluminium diffuser (safe, silent and long-lasting)
-  Automatic over heat safety device
-  Front air outlet wings
-  Class II and IP24 protection with dual electric insulation for ultimate safety

\*compared with a mechanical convector

## Dimensions

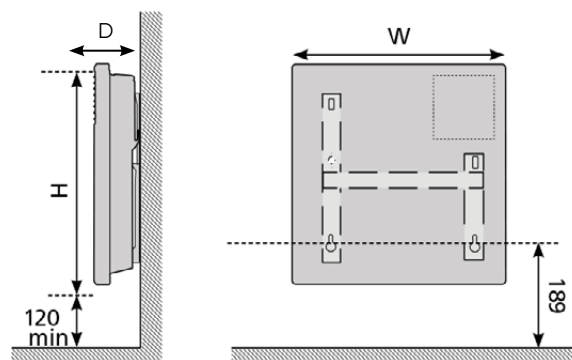

## F127 technical data

OUTPUT (W)	DEPTH (MM)	WIDTH (MM)	HEIGHT (MM)	WEIGHT (KG)	MODEL
500	102	370	453	3.8	AH500101
750	102	370	453	3.8	AH500106
1000	102	447	453	4.2	AH500103
1250	102	517	453	4.4	AH500107
1500	102	590	453	5.5	AH500104
2000	102	740	453	6.8	AH500105

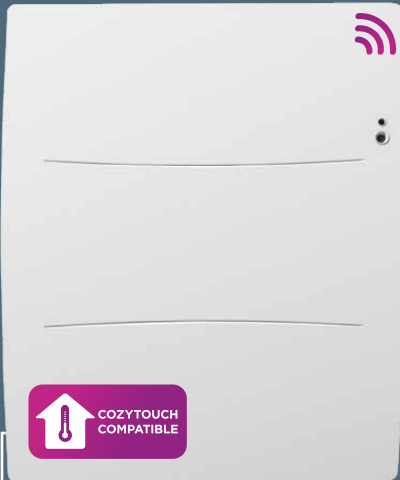

## Description

- 500 to 2000W
- Built in energy saving features
- Smart control functionality
- Colour: RAL9016 White



The Agilia IO takes the smart features of the Agilia Digital and adds Cozytouch compatibility allowing the user to control these features through their smartphone\*. With integrated absence and presence detectors, the Agilia IO adapts to your lifestyle and, even in it's stylish and compact form. It can also heat up quickly thanks to it's double heating element.



\*Requires additional CozyTouch bridge

## Key features

-  Open window detection
-  Absence and Presence detection
-  3 programming modes manual, prog, (24 hour 7 day timer) and IO
-  High-Precision Electronic thermostat
-  Digital screen, LCD digital controls
-  Stylish electric radiator with double heating element for fast heating
-  Energy consumption indicator
-  IP24 rated
-  Lock function

## Dimensions

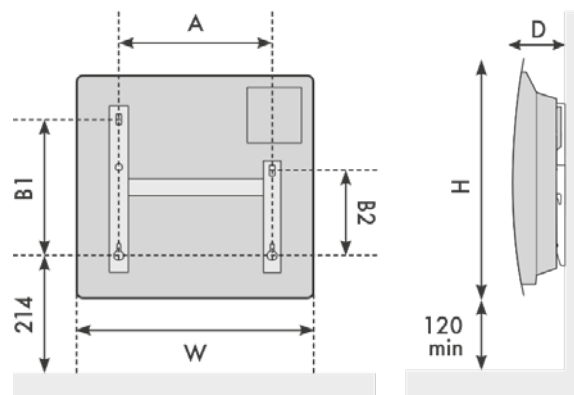

## Agilia technical data

OUTPUT (W)	DEPTH (MM)	WIDTH (MM)	HEIGHT (MM)	A	B1	B2	WEIGHT (KG)	MODEL
500	129	372	530	120.8	246	158.5	5.5	AH503105
750	129	372	530	120.8	246	158.5	5.5	AH503107
1000	129	446	530	194.8	246	158.5	6	AH503110
1250	129	520	530	268.8	246	158.5	7.5	AH503117
1500	138	594	530	342.8	246	158.5	9	AH503115
2000	138	742	530	490.8	246	158.5	9	AH503120

# Accessio

Electric thermofluid radiator

2 YEAR  
WARRANTY

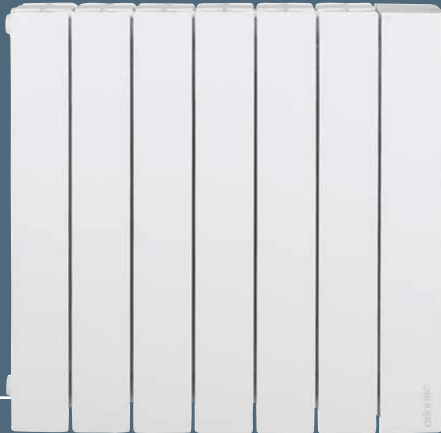

## Description

- 300 to 2000W
- Built in energy saving features
- User friendly
- Manual or Programmed
- Colour: RAL9016 White





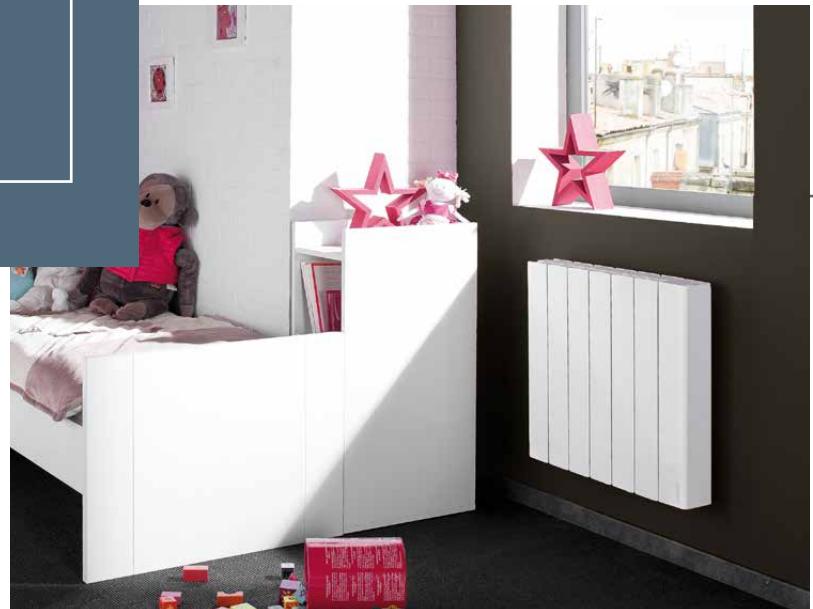



The Accessio is an easy to use electric, heat conducting fluid-filled radiator that delivers homogeneous long-lasting heat as a result of integral thermofluid technology. Not only that, user friendly digital controls and an electronic thermostat can help homeowners achieve energy savings of up to 25% versus conventional electric heating solutions.\*



\* Compared to a mechanical convector

## Key features

-  Open window detection
-  2 modes: Manual/Prog 24 hour 7 day timer
-  6-command pilot wire: Comfort, Comfort -1°C, Comfort -2°C, Eco, Frost-free, Off
-  High-precision electronic thermostat
-  Up to 25% energy savings\* through accurate digital control and programming
-  Thermofluid technology providing homogeneous & long-lasting heat, and no dry air
-  ASP (Anti-Staining Process) to reduce staining on wall and on equipment

## Dimensions

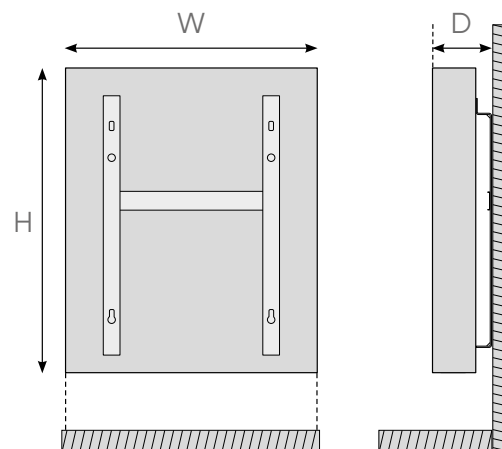

## Accessio technical data

OUTPUT (W)	DEPTH (MM)	WIDTH (MM)	HEIGHT (MM)	WEIGHT (KG)	MODEL
300	127	410	575	8.5	AH524903
500	127	410	575	8.5	AH524905
750	127	490	575	9.9	AH524907
1000	127	490	575	9.9	AH524910
1250	127	651	575	13.2	AH524912
1500	127	732	575	14.8	AH524915
2000	127	973	575	19.7	AH524920

# Galapagos

Electric thermofluid radiator

2 YEAR  
WARRANTY



## Description

- 3 models: 700 to 2000W
- Built in energy saving features
- Smart control functionality
- Cozytouch compatible\*











The Galapagos is a stylish, electric, fluid-filled radiator that distributes uniform heat from its entire surface using thermofluid technology. The Galapagos electric radiator has an AUTO mode which is an in-built smart control function that tracks the user's requirements and room occupancy and adapts heating to comfort or eco mode accordingly. It also features open/closed window detection that switches the heater to a minimum output when a window is opened. The Galapagos has a stylish, curved aluminium front panel ideal for modern homes and kitchens.

\*Requires additional CozyTouch bridge





## Key features

-  In built smart control function tracks the user's requirements and room occupancy, adapting heating to comfort or eco mode accordingly (AUTO mode)
-  Open window detection
-  3 programming modes manual, prog, (24 hour 7 day timer) and IO
-  High-precision electronic thermostat
-  Thermofluid technology - heating element immersed in a heat transmitting fluid
-  Consumption indicator for responsible, informed use of the equipment
-  Class II and IP24 protection with dual electric insulation for ultimate safety
-  ASP (anti-dust) technology
-  Available in White and Greystar



# Galapagos Range

Electric thermofluid radiator

## Standard



2 YEAR WARRANTY

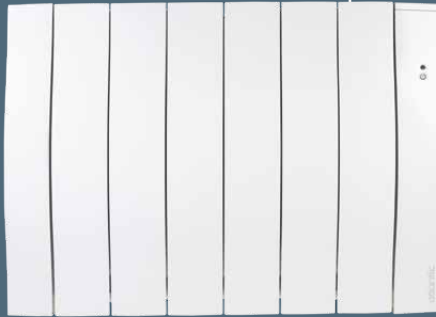

OUTPUT (W)	DEPTH (MM)	WIDTH (MM)	HEIGHT (MM)	WEIGHT (KG)	A	B	WHITE MODEL	GREYSTAR
750	130	670	590	12.4	300	354	AH500607	AH501845
1000	130	770	590	14.4	400	354	AH500610	AH501846
1250	130	970	590	18.4	600	354	AH500612	AH501847
1500	130	1070	590	20.4	700	354	AH500615	AH501848
2000	130	1370	590	26.4	800	354	AH500620	AH501849



## Low height



2 YEAR WARRANTY

2100  
Greystar

RAL9016  
White

OUTPUT (W)	DEPTH (MM)	WIDTH (MM)	HEIGHT (MM)	WEIGHT (KG)	A	B	WHITE MODEL	GREYSTAR
700	133	771	388	11	400	158	AH502907	AH501853
1000	133	971	388	15	600	158	AH502910	AH501854
1400	133	1371	388	21	800	158	AH502915	AH501855

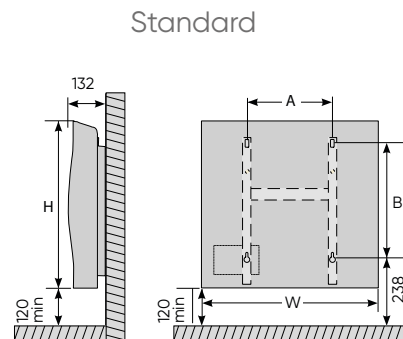

## Low height

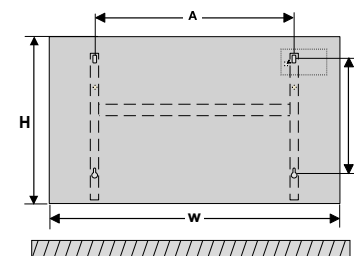

## Vertical

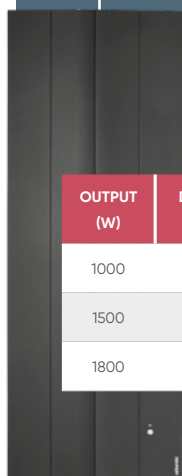

RAL9016  
White

2 YEAR WARRANTY

2100  
Greystar

OUTPUT (W)	DEPTH (MM)	WIDTH (MM)	HEIGHT (MM)	WEIGHT (KG)	A	B	WHITE MODEL	GREYSTAR
1000	133	460	1290	24	320	1021	AH501310	AH501850
1500	133	460	1590	29	320	1321	AH501315	AH501851
1800	133	460	1800	33	320	1521	AH501320	AH501852

## Vertical

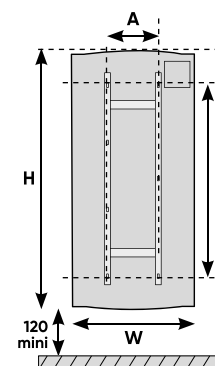

# Oniris

Electric radiator

2 YEAR  
WARRANTY

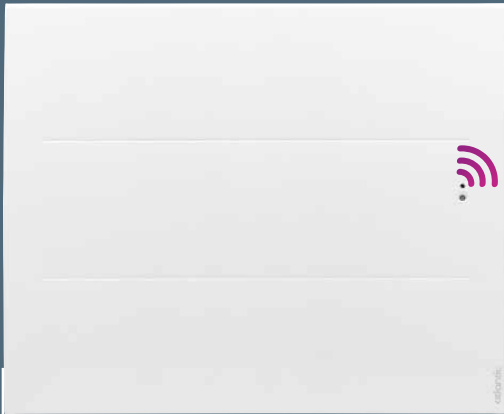

## Description

- 750 to 2000W
- Built in energy saving features
- Smart control functionality
- Compatible with CozyTouch
- Colour: RAL9016 White











The Oniris is a very stylish, digital, electric panel heater featuring a modern aluminum surface and heating element for warmth with style. Complete with occupancy detection, which automatically reduces heat if the room is empty, and open window detection that will switch the heater to a minimum output.



\*Requires additional CozyTouch bridge

## Key features

-  In built smart control function tracks the user's requirements and room occupancy, adapting heating to comfort or eco mode accordingly (AUTO mode)
-  Open window detection
-  Presence / absence detection feature – will automatically reduce heat if room is empty
-  3 programming modes manual, prog, (24 hour 7 day timer) and IO
-  High-precision electronic thermostat
-  45% of radiant heating, faster warm up
-  Aluminium heating element with additional heating film
-  Consumption indicator for supreme energy efficiency
-  IP24 rated

## Dimensions

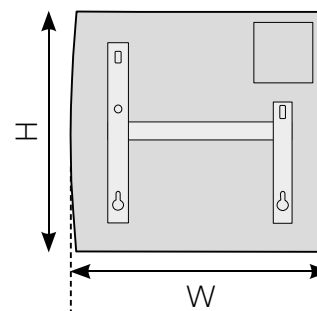
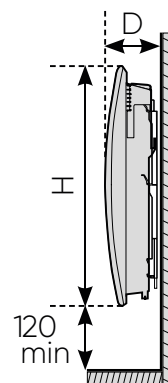







## Oniris technical data

OUTPUT (W)	DEPTH (MM)	WIDTH (MM)	HEIGHT (MM)	WEIGHT (KG)	MODEL
750	110	613	615	10.8	AH503907
1000	110	761	615	13	AH503910
1250	110	909	615	15.4	AH503912
1500	110	1058	615	18	AH503915
2000	110	1205	615	20.4	AH503920

# Cozytouch



## Key features

-  Bridge allows control of connected Atlantic products
-  LED indicator
-  Connects to internet router via supplied ethernet cable
-  User account required (on set up)
-  Prog/Prog reset button
-  Power supply lead included

Cozytouch requires internet connection



Cozytouch allows you to control your heating remotely from your phone or tablet. Offering real-time monitoring such as energy consumption, absence detection and open window detection, Cozytouch means you can set the temperatures you want for when you want them.

## Technical data

DEPTH (MM)	WIDTH (MM)	HEIGHT (MM)	MODEL
110	71	28	AH001231

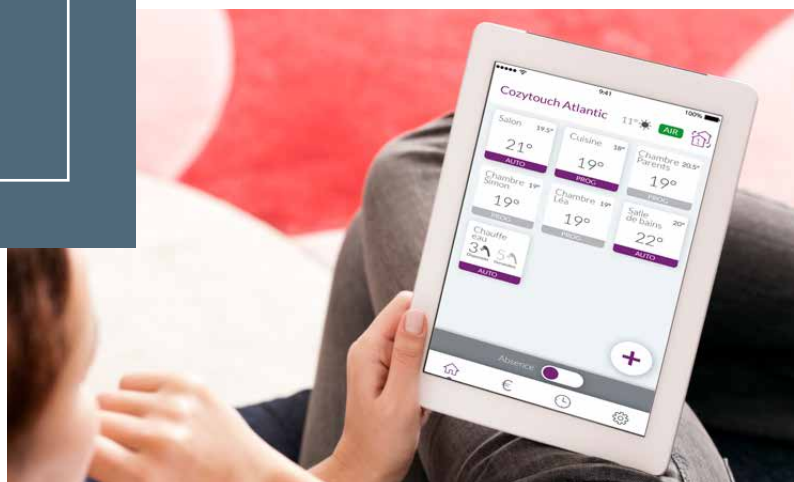

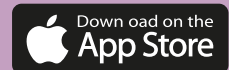

APP AVAILABLE  
TO DOWNLOAD  
FOR FREE!



Here are just a few of the features of the Cozytouch smart app:



Real time monitoring



Absence detection



Daily energy management



Synchronize temperatures



Open window detection



Control individual or multiple paired devices



Compatible with\*



Agilia IO

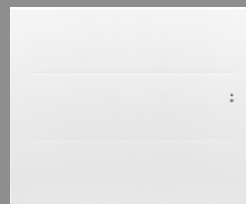

Oniris

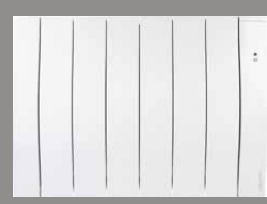

Galapagos

\*Pairing function available on all IO compatible heaters

# LST HEATER

Low surface temperature

1 YEAR  
WARRANTY

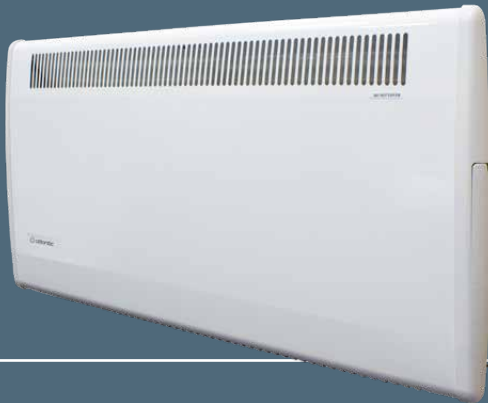

## Description

- 500 to 1500W
- NHS safety compliant
- Sheathed heating element
- Colour: RAL9016 White













The LST, Low Surface Temperature, electric radiator is a convector heater specifically designed to comply with the NHS Health Estate Guidelines. The inbuilt safety functions and modulating fan speed\* ensures that the LST only ever achieves a maximum surface temperature of 43°C. The concealed digital controls allow for 24 hour/7 day programming along with boost and setback options.





## Key features

-  Easy prog: 24 hour/7, program your device according to your life rhythm for greater comfort and savings
-  Maximum surface temperature of 43°C to comply with NHS Estates Health Guidance Notes
-  IP24
-  Concealed digital controls
-  Open window detection
-  Hinged wall mounting system for easy installation
-  4 large control buttons with audible and tactile feedback
-  Intelligent Fan Control\*
-  4 operating modes: Programme, Boost, Setback and Comfort
-  Electronic lock to prevent tampering with controls

## Dimensions

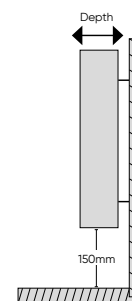
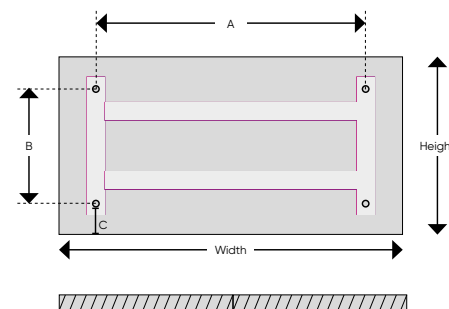

## LST technical data

OUTPUT (W)	DEPTH (MM)	WIDTH (MM)	HEIGHT (MM)	WEIGHT (KG)	A	B	MODEL
500	93	506	430	5.5	210	270	225449
750	93	506	430	5.5	210	270	225450
1000	93	640	430	6.0	364	270	219456
1500	93	892	430	8.0	616	270	219457

# Air Curtain



## Description

- Selectable heat outputs
- Easy installation
- Lightweight
- Colour: RAL9016 White



A welcoming curtain of warmth for doorways in shops, hotels, offices and other commercial premises.



Site an air curtain above a frequently opened external door to help prevent heat loss and save energy.



## Key features

-  3 heat settings
-  Fan only setting for air circulation
-  Automatic safety cut-out for thermal overload protection
-  Fitted with integral switches
-  3kW & 4.5kW models
-  Wall mounting bracket supplied
-  Alternatively, the heater can be suspended, wall or trunking mounted
-  Optional remote switch

## Dimensions

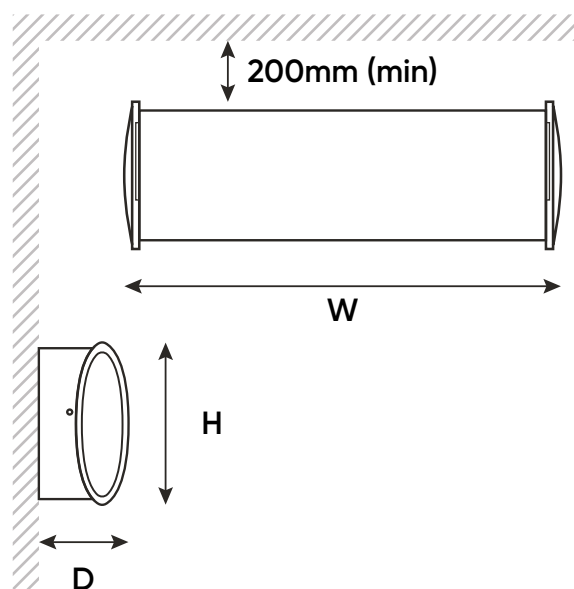

## Air Curtain Technical Data

OUTPUT (W)	DEPTH (MM)	WIDTH (MM)	HEIGHT (MM)	WEIGHT (KG)	MODEL
3000	115	634	210	5.1	AH303000
4500	115	634	210	5.1	AH304500
Optional wired switch					AH305005

# Sensis

Electric towel dryer

2 YEAR  
WARRANTY



## Description

- Digital electronic thermostat
- IP24 rated
- ErP compliant towel dryer



RAL9016  
White



The Sensis towel dryer uses thermofluid technology and has been designed for comfort and simplicity. Sensis features an integrated programmer, integral, adjustable thermostat with up to 60 minute Boost timer. For use with a third party control use the Sensis 200W with simple On/Off switch control.



## Key features

- Open Window detection
- 2 program modes: Comfort and Eco
- Up to 60 Minute boost timer
- High-Precision Electronic thermostat
- Class II and IP24 protection with dual electric insulation for ultimate safety
- Thermofluid technology providing homogeneous & long-lasting heat, and no dry air

## Dimensions

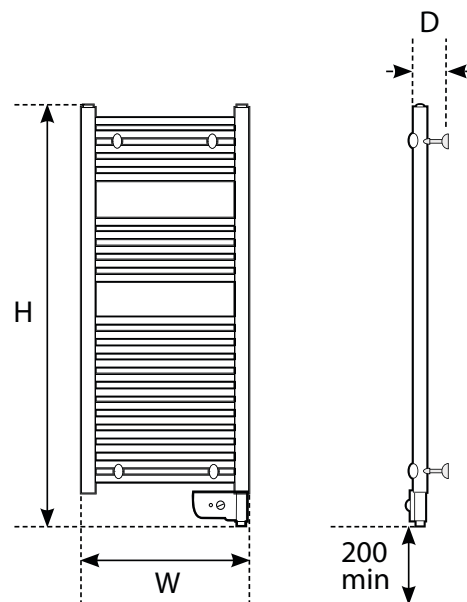

## Sensis Technical Data

OUTPUT (W)	DEPTH (MM)	WIDTH (MM)	HEIGHT (MM)	WEIGHT (KG)	MODEL
200	100	400	584	6	AH100836
300	100	400	720	7	AH100837
500	100	500	884	9	AH100838

# Atlantic Direct



## Description

- 25 Year Warranty
- Solar Photovoltaic
- Immersion heater

25  
YEAR

25 YEAR  
WARRANTY



SOLAR  
PHOTOVOLTAIC



IMMERSION  
HEATER



Unvented direct mains pressure hot water cylinders

## Key features



Designed with flat top to increase insulation



Aligned tapping positions promote easier installation



Colour matched components for visual appeal



Wide base to improve unit stability



Durable rubber connection labels and caps with foam retention



External expansion allows for installation in height restricted areas and easier servicing



Suitable for use with economy electricity tariffs to maximise efficiency



Designed for use with electricity either from mains supply or photovoltaic panels

## Dimensions

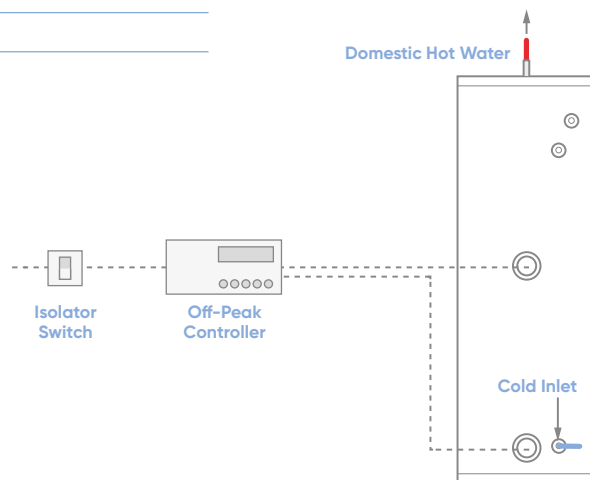

## Atlantic Direct Technical Data

DESCRIPTION		D90	D120	D150	D180	D210	D250	D300
PRODUCT STOCK CODE		ATLPRODR090	ATLPRODR120	ATLPRODR150	ATLPRODR180	ATLPRODR210	ATLPRODR250	ATLPRODR300
ERP RATING		C	C	C	C	C	C	C
HEAT LOSS	WATTS	32	39	47	55	62	74	86
CAPACITY	LITRES	91	119	148	178	208	248	287
HEIGHT	MM	764	931	1118	1306	1494	1744	1990
DIAMETER	MM	550	550	550	550	550	550	550
WEIGHT (EMPTY)	KG	18	21	25	28	32	36	41
WEIGHT (FULL)	KG	109	140	173	206	240	284	328
HEAT UP TIME	MIN	90	119	150	179	209	249	299
NUMBER OF IMMERSIONS		1	2	2	2	2	2	2
SECONDARY RETURN		NO	NO	NO	NO	YES	YES	YES

# Why choose electric heating?

Electric heaters are 100% efficient at the point of use, meaning all electricity used is converted into heat.

Because electric heaters have virtually no moving parts, most systems can provide great longevity and reliability than alternative ways of heating.

The Energy related Product (ErP) Directive aims to reduce carbon emissions across Europe by phasing out low efficiency products, for electric heating the directive requires that local space heaters comply with the minimum efficiency standard.

## Here is our ErP compliant promise to you:

- ✓ Our heaters perform to a high efficiency saving you energy and money on bills.
- ✓ All heaters will include open-window detection offering additional control to save energy.
- ✓ Every heater has an integral temperature control which offers 24 hour and 7 day timers.
- ✓ Users can benefit from additional smart functions from distance heating control and monitoring via the Cozytouch app.



## Future Proofing

Electric heaters can provide a major advantage in home extensions when existing gas central heating systems lack sufficient capacity to heat additional radiators.





### **Electric heating**

Electricity is increasingly being produced from renewable sources reducing the level of carbon intensity. Thermal losses and associated energy consumption have considerably reduced as a result of improvements to the fabric of buildings. Electric heating provides a solution that is 100% efficient at the point of use where every kWh paid for is converted into heat. Electric heating can be controlled with a higher degree of accuracy than other systems offering room by room control which can react quickly to supplementary heat gains, electric heating requires almost no annual maintenance whilst offering greater reliability and a lower capital installation cost.

### **Convected heat**

Convected heat is carried around a room in the form of heated air. Air is drawn across a heating element inside the electrical heater and circulated into the room. Heated air is lighter and diffuses the colder air which is denser and raises the ambient temperature. The hotter the electric heater's heating element, the further the convected heat will flow before diffusing into the air.

### **Building Regulations**

Building Regulations Approved Document Part L demands that appropriate steps are taken for the conservation of energy by limiting heat loss and heat gain through the material of a home as well as addressing the efficiency of heating, lighting and ventilation. Part L1A applies to the conservation of fuel and power in new dwellings in England. Part L1B applies to conservation of fuel and power in existing dwellings in England. Part L1A requires that reasonable provision is made for the conservation of fuel and power in buildings by limiting heat gains and losses through thermal elements and other parts of the building fabric and providing fixed building services that are energy efficient and have effective controls to ensure they use no more power than is reasonable in the circumstances.

### **Radiant heat**

Unlike convected heat, radiant heat does not rely on the direct heating of air. It relies instead on electromagnetic infrared waves which transfer the energy and release it as heat once it strikes an object. It's this type of heat we get from the sun and an open flame.

### **Safety**

Because electric heaters do not burn fuel internally to generate heat, there are none of the associated risks such as carbon monoxide poisoning. This gives electric heaters a greater margin of safety over conventional central heating systems and there is no requirement for an annual safety certificate.

### **Cost**

Electric heating and hot water solutions can be a preferred choice amongst housing professionals in certain installations such as flats and apartments due to lower capital costs, faster installation times and system layout flexibilities when compared to conventional heating systems. It is entirely suited to second stage fixing in new builds or for renovations with minimal disruption relying only on a simple connection to the electrical circuits. An electric heater can be installed in matter of minutes and can be operated independently or as part of a heating system.



[atlantic-heat.co.uk](http://atlantic-heat.co.uk)

T: Sales Support: 0844 335 0549 Technical Support: 01482 498220

E: Technical Support: [Technical-Support@atlantic-heat.co.uk](mailto:Technical-Support@atlantic-heat.co.uk)

Sales Support: [Sales-Support@atlantic-Heat.co.uk](mailto:Sales-Support@atlantic-Heat.co.uk)

Atlantic Heat | PO Box 103, National Avenue,  
Kingston Upon Hull, HU5 4JN

Atlantic Heat is part of Ideal Boilers Limited. Ideal Boilers Ltd. pursues a policy of continuing improvement in the design and performance of its products. The right is therefore reserved to vary specification without notice.