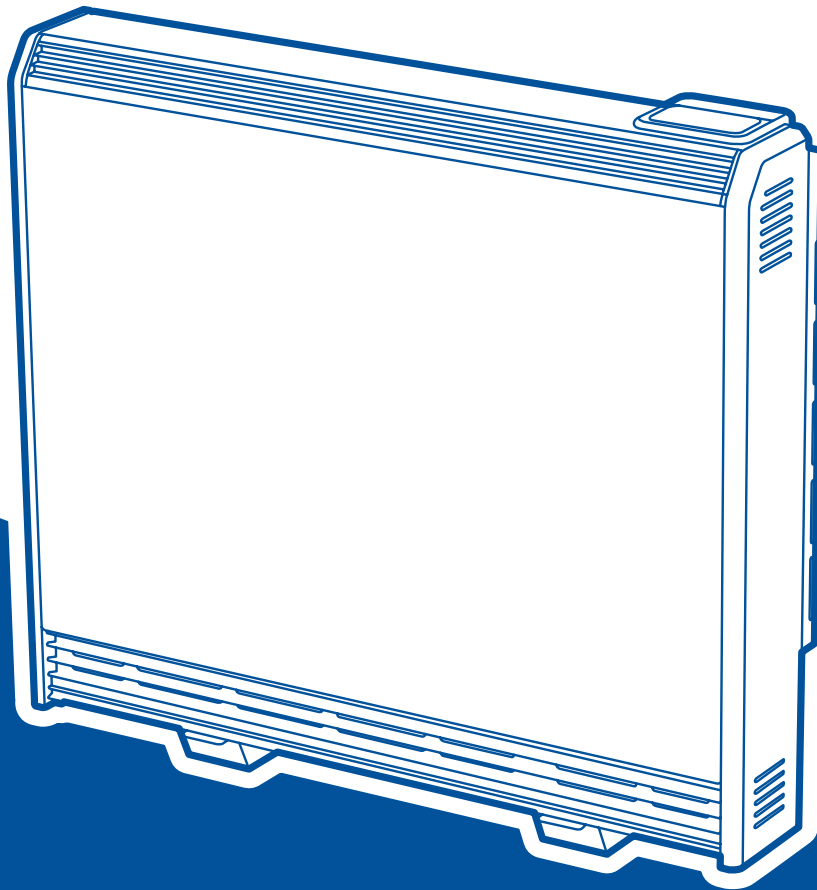


# Creda

HEATING

## INSTRUCTION MANUAL

Installation and Operating



### **Creda TSRE Storage Heater**

Models: TSRE050 / TSRE070 / TSRE100 / TSRE125 / TSRE150

These instructions should be read carefully and retained for future use. Note also the information presented on the appliance.



## IMPORTANT

THESE INSTRUCTIONS SHOULD BE READ CAREFULLY AND RETAINED FOR FUTURE REFERENCE. **Note also the information presented on the appliance**

## CAUTION

FAILURE TO FOLLOW THESE INSTRUCTIONS MAY CAUSE INJURY AND/OR DAMAGE AND MAY INVALIDATE YOUR GUARANTEE

## IMPORTANT SAFETY ADVICE

When using electrical heaters, basic precautions should always be followed to reduce the risk of fire, electrical shock, and injury to persons, including the following:

**IMPORTANT** – The wall bracket supplied with the heater must be used.

**IMPORTANT** – All packaging should be disposed of in an appropriate manner.

## OVERHEATING WARNING

**WARNING** - In order to avoid overheating, do not cover or obstruct the heater. Do not place material or garments on the heater, or obstruct the air circulation around the heater, for instance by curtains or furniture, as this could cause overheating and a fire risk. **NEVER** cover or obstruct in any way the heat outlet slots at the top of the heater or the air outlet slots in the base of the heater.

## WARNING - THE SURFACES ON THIS HEATER CAN BE HOT.

The heater carries a warning 'DO NOT COVER' to alert the user to the risk of fire that exists if the heater is accidentally covered.



**CAUTION** - Some parts of this product can become very hot and cause burns. Particular attention has to be given where children and vulnerable people are present.

For your safety this heater is fitted with a thermal cut-out. In the event that the product overheats for some reason, the cut-out prevents excessive temperatures on the product by cutting the power to the heater. Once the heater has cooled down, it will reset automatically, it will continue to cycle on and off automatically until the reason for overheating is removed.

The display screen may flash red to indicate the product has overheated. To reset the display, remove the obstruction and hold Enter for 10 seconds.

## SUITABLE APPLICATIONS

**WARNING** - This heater is suitable for normal domestic household purposes and should not be used in any other type of environment. This product should only be used in the country where it was purchased from by a recognised commercial retailer. **Do not use outdoors.**

## SERVICING AND REPAIRS

**WARNING** - Servicing and product repairs should only be undertaken by the manufacturers approved service agent or a similarly trained or qualified person, using only exact manufacturer approved spare parts.

**PLEASE NOTE:** Household dust, lit cigarettes, candles and oil burners, combined with the convection effect of electric heaters can cause significant soot deposits to build up on the surface directly above and to the sides of the heater. This is not a fault of the heater. Extensive burning of candles or smoking in the operating environment of this product can produce heavy discolouration within a few months of use.

## OPERATING WARNINGS

**IMPORTANT:** Remember to observe all safety warnings and precautions when operating the heater on the automatic or timer modes, either attended or unattended since a fire risk exists when the heater is accidentally covered or obstructed.

Mains cables are not provided with this heater.

**CAUTION:** Do not use if either of the heater's mains power leads become damaged. If the supply cord is damaged it must be replaced by the installer or an approved service partner.

Curtains must not come to within 250mm of the top of the heater.

Do not sit or stand on the heater

Do not place objects in contact with the heater.

To maintain stability, it is essential that the heater is placed on a level surface and care should be taken to avoid irregular surfaces, such as may result from carpets or tiled surrounds partially protruding under the heater.

## ELECTRICAL INSTALLATION

**The installation of the heater should be carried out by trained personnel.**

**WARNING - Minimum clearances and IP zone requirements must be adhered to in accordance with the current wiring regulations.**

**WARNING** - The electrical installation of this heater must be carried out by a suitably qualified or trained electrician, and be in strict accordance with current wiring Regulations. The peak supply must be connected via a switched fused spur with a fuse rated suitably for the appliances flex, the off-peak supply, via a 20A double pole switch. Failure to follow these instructions will mean that the manufacturer's instructions have not been adhered to. THERE ARE NO EXCEPTIONS.

- This heater must be earthed
- Not suitable for connection via a plug top
- Do not locate the heater immediately above or below a fixed electrical point i.e. socket outlet.

This appliance is intended for installation to a single phase supply only and is not suitable for connection to 3 phase supplies.

The heater is not fitted with a mains cable, this should be fitted by the installer. Cable type (minimum size) H05VV-F 1.5mm<sup>2</sup> three core for peak and 2.5mm<sup>2</sup> three core for off-peak for connection to the fixed wiring of the premises through suitable isolation devices positioned adjacent to the heater. The supply circuits to the heater must incorporate a double pole isolating switch having a contact separation of at least 3mm.

In installation the supply cord may be cut to the appropriate length for the electrical connection point. Excess cable should not be inserted or stored behind the heater.

If, during reassembly of the heater, a part of the thermal insulation shows damage or deterioration, it should be replaced by an identical part.

**WARNING:** All electrical connections to the terminal block must be secure to prevent risk of ignition. Tighten to 0.5 Nm.

## CHILD SAFETY

**WARNING** - Fixing kit screws are a potential choking hazard.

**WARNING** - This appliance is not intended for use by persons (including children) with reduced physical, sensory or mental capabilities, or lack of experience and knowledge, unless they have been given supervision or instruction concerning use of appliance by a person responsible for their safety.

This appliance can be used by children from 8 years and above and persons with reduced physical, sensory or mental capabilities or lack of experience and knowledge if they have been given supervision or instruction concerning use of the appliance. Children shall not play with the appliance. Cleaning and user maintenance shall not be made by children without supervision. Children of less than 3 years should be kept away unless continuously supervised. Children aged from 3 years and less than 8 years shall only switch on/off the appliance provided that it has been placed or installed in its intended normal operating position and they have been given supervision or instruction concerning use of the appliance in a safe way and understand the hazards involved. Children aged from 3 years and less than 8 years shall not regulate and clean the appliance or perform user maintenance.

## Technical Details

Models	TSRE050	TSRE070	TSRE100	TSRE125	TSRE150
Input Rating +5% / -10%	1020W	1560W	2220W	2760W	3300W
Nominal Output (kW)	0.50	0.70	1.00	1.25	1.50
Storage Element Rating 230/240V~:	936/1020W	1435/1560W	2042/2220W	2540/2760W	3024/3300W
Rated Charge Period:	7.7 - 7 Hours	7.7 - 7 Hours	7.7 - 7 Hours	7.7 - 7 Hours	7.7 - 7 Hours
kWh:	7.14kWh	10.9kWh	15.5kWh	19.3kWh	23.1kWh
Fan Wattage	11W	11W	11W	11W	11W
UI Wattage	0.5W	0.5W	0.5W	0.5W	0.5W
Sound Level dB	27	29	32	30	31
Energy Cell Packs Required (047243)	4	6	8	10	12
Installed Weight:	63kg	85kg	107kg	133kg	155kg
Height (mm)	749	749	749	749	749
Width (mm)	581	703	825	947	1069
Depth (mm)	182	182	182	182	182

All Models	
Controls	Digitally controlled, Electronic Thermostat accurate to ( $\pm 0.2^{\circ}\text{C}$ ). Setpoint range (7-26 $^{\circ}\text{C}$ ) Timer modes: 7 Day Programmable User Timer, Out All Day, Holiday
Controller UI	<ul style="list-style-type: none"> <li>•Graphical display with white backlight</li> <li>•Capacitive buttons with audio feedback</li> <li>•User replaceable battery (Coin-Type)</li> </ul>
Controller Functions	<ul style="list-style-type: none"> <li>•Open window detection</li> <li>•Boost Mode and Settings</li> <li>•Heat Demand % Adjustment</li> <li>•History/Reporting</li> <li>•Automatic Charge Control</li> <li>•Bluetooth for software updates</li> <li>•Child Lock</li> </ul>
Safety Features	Electronic overheat protection. Additional electromechanical overheat protection. LVD and EMC compliance.
Storage Core	High-density bonded magnetite energy cells
Colour/ Finish	White (RAL 9016) 'Traffic White'. Grill RAL7035 anodised
Battery Backup	3.3V coin cell battery to backup real time clock. Battery life > 5 years.
Supply (each)	1/N/PE 230-240V / 50Hz (Peak / Off Peak) Class II
IP Rating	IPX4
Approvals	CE & BEAB
Warranty	2 Years
Country of Origin	United Kingdom

# Preparation

1. Place the heater within its packaging flat on the ground with arrows printed on the base of the carton pointing upwards.
2. Feet are fitted in the default position (**X** position) and can be moved to the outside position (**Y** position) if necessary. (**Fig. 1a** and **Fig. 1b**). NB: Repositioning of feet may be required depending on floor arrangement (e.g. replacing an installation).

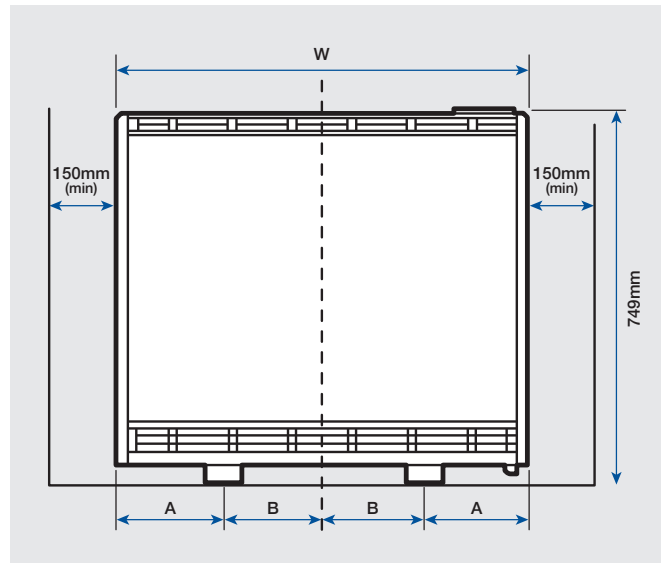
Stand the heater on its feet before removing the packaging.

**CAUTION SHOULD BE TAKEN NOT TO REST THE HEATER UPON THE ROOM TEMPERATURE SENSOR HOUSING. (Fig. 1b)**

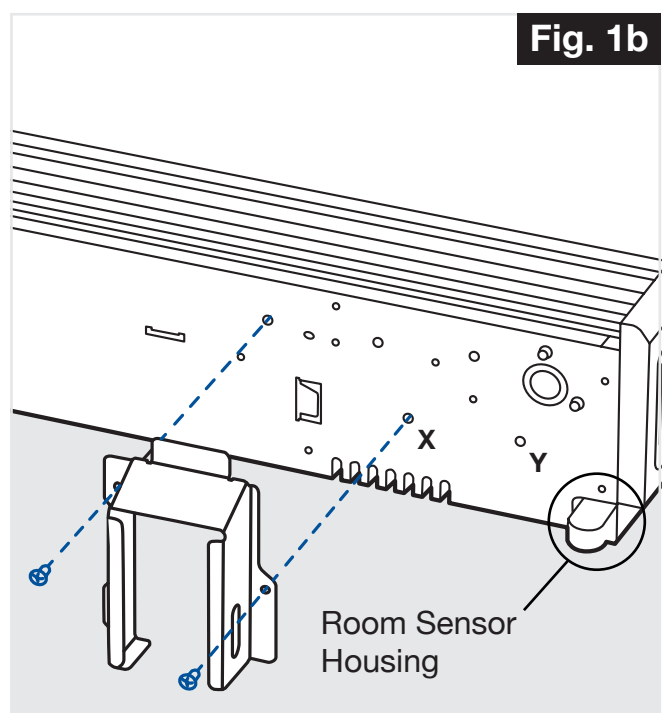
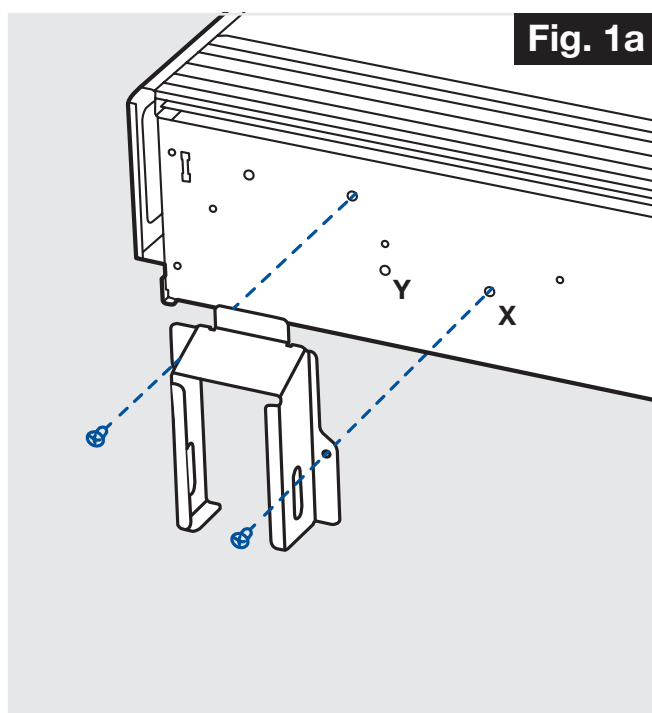
Dispose of packaging in an appropriate way. Read these instructions carefully before proceeding any further with the installation.

3. Ensure the heater is stable before removing the screws which hold the bottom grille panel in position. (**Fig. 2**) Set the bottom grille to one side, avoiding its sharp edges when handling.
4. Remove the two screws securing the front panel, located at the bottom of the heater (**Fig. 3**). Once removed set carefully to one side to avoid damage.

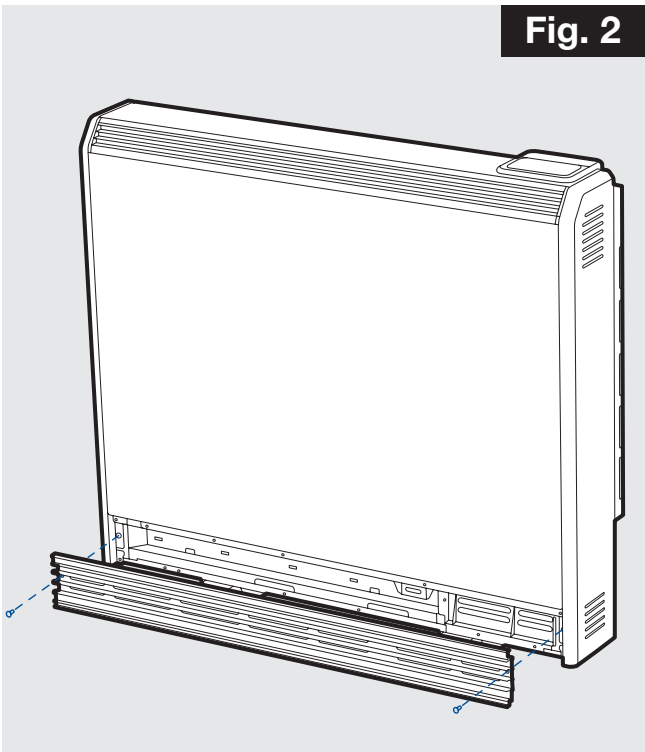
**NOTE - Retain these screws for reassembly. If misplaced, M4 x 10 Tritap screws must be used. IMPORTANT - Do not use the outer top panel or the rear heat shield to lift or carry the heater.**



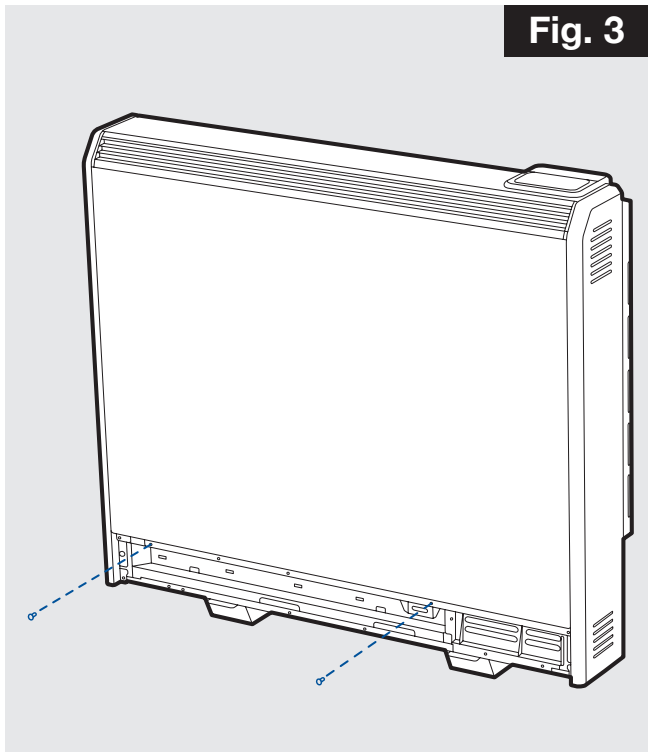
Models	050	070	100	125	150
Feet Position 1 'A/B'	167/124	167/185	167/246	160/314	160/375
Feet Position 2 'A/B'	93/198	93/259	93/320	100/374	100/435



**Fig. 2**

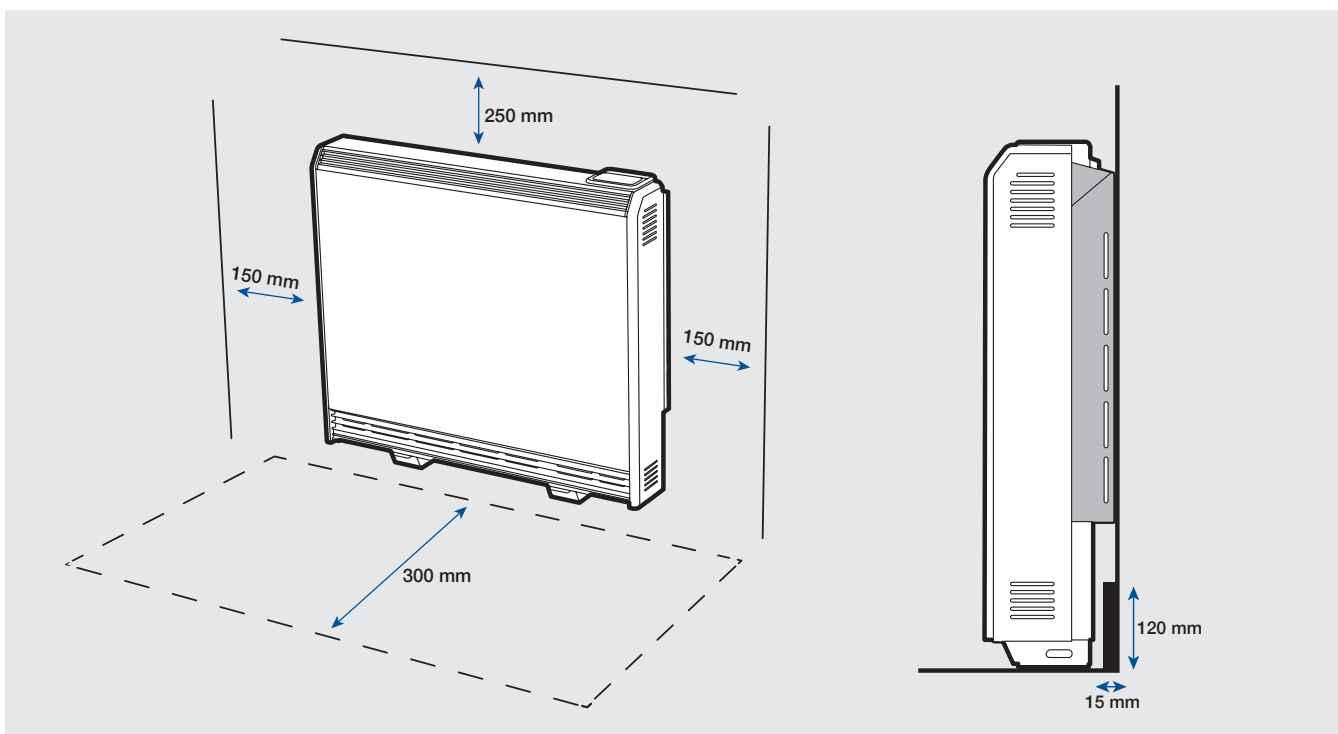


**Fig. 3**



Ensure the back of the heater is flush against the wall. If the skirting board is taller than 120mm and deeper than 15mm it should be cut to accommodate safe installation of the heater.

Do not place objects within 300mm of the front of the heater and 150mm (min. 75mm) either side.



## Installing the Heater

**IMPORTANT** Head of wall fixing screw must be flanged pan head type and have a diameter no less than 11mm. No countersunk headed screws to be used for wall fixing.

The heater must be securely fixed to a wall. Screws with suitable wall fixings for solid walls are provided. If other wall types are encountered it is the installer who must choose the most suitable fixing.

### SUGGESTED FIXINGS

**SOLID BRICK/BLOCK:** No. 10 size high temperature resistant plastic inserts, 8mm drill bit. Drill hole 15mm deeper than plastic insert length.

**PLASTERBOARD** - If possible locate studding and use No. 10 woodscrews directly into the wood, otherwise M5 rawlplug intersets are suitable.

**NOTE: FOR OTHER WALL TYPES** (eg. timber frame and hollow concrete) SEEK SPECIALIST ADVICE.

If the floor is carpeted then the carpet should be slit and underlay cut away to allow the feet to rest firmly on the floor. Carpet gripper must be locally removed so that the feet may rest in a level position.

This appliance is heavy. The floor must be checked to ensure that it is capable of bearing the weight of the unit, up to 165kg.

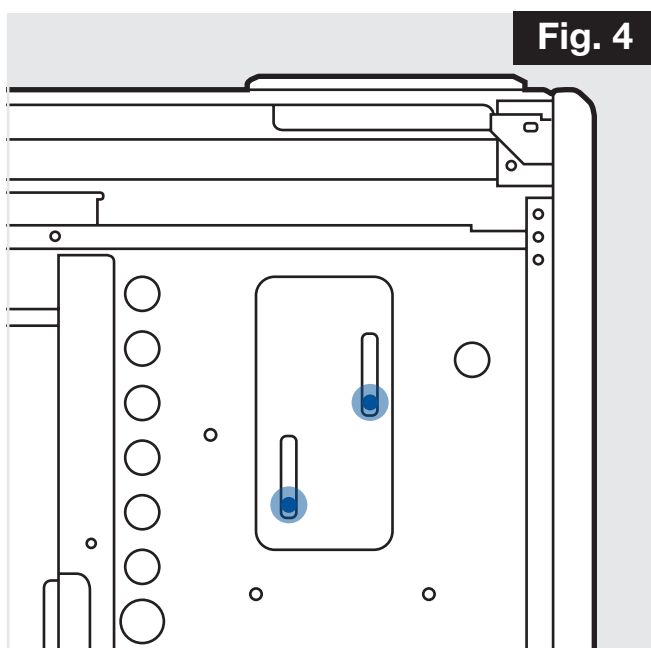
**This Heater is rated IPX4**



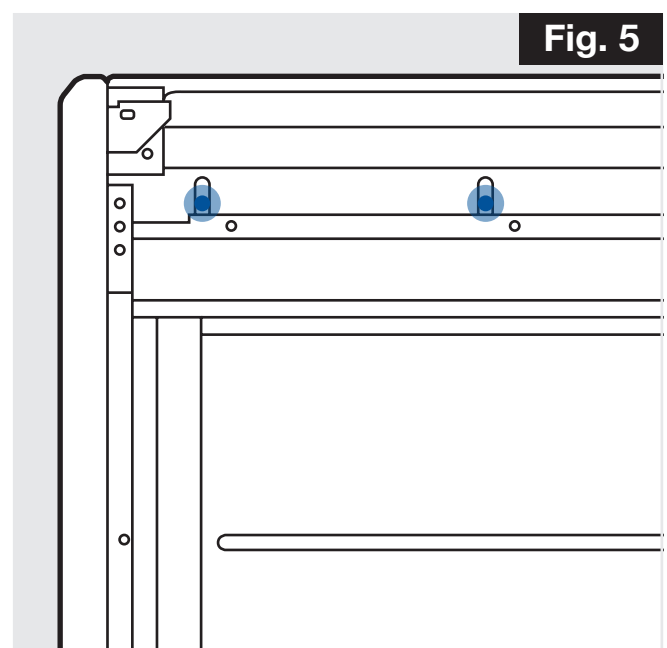
**DO NOT UNDER ANY CIRCUMSTANCES ATTEMPT TO MOVE OR REPOSITION THIS HEATER WITHOUT SEEKING EXPERT ADVICE. THE HEATER SHOULD NEVER BE FREED FROM THE WALL WITH ENERGY CELLS INSIDE.**



**USE CAUTION WHEN INSTALLING THIS PRODUCT, UNPAINTED METALWORK CAN HAVE SHARP EDGES.**



**Fig. 4**



**Fig. 5**



**NOTE: ANY FIXING DROPPED INTO HEATER MUST BE RETRIEVED AS THEY MAY IMPACT PRODUCT SAFETY OPERATION.**

5. Place the heater in its final position and mark the fixing holes through the location holes visible through the back of the heater.

6. Six fixing positions must be selected for models TSRE100, TSRE125, TSRE150 and at least 4 fixing positions for models TSRE050 and TSRE070. **Fig. 6.**

Common fixing points for all heater sizes are shown in both **Fig. 4** and **Fig. 5**.

Mark the positions for the fixing holes towards the bottom of each slot. This allows the heater to settle once the energy cells have been fitted.

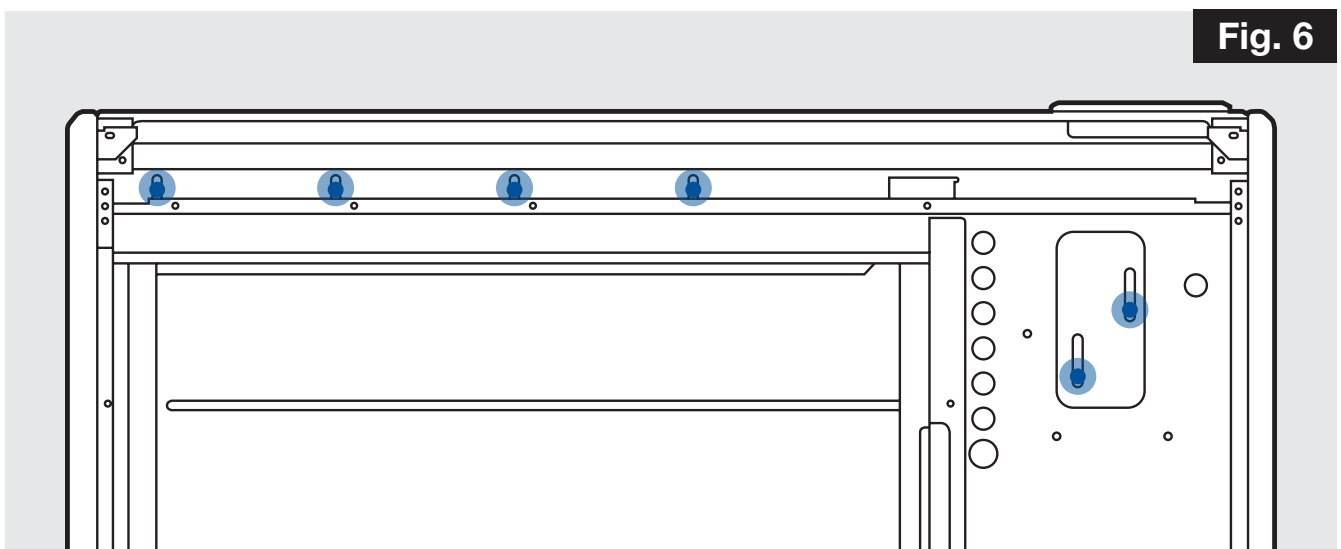
Move the heater away from the wall, drill the holes and fit the wall fixings best suited to the application.

Secure the heater to the wall using correct quantity of screws required per model, using the appropriate screw fittings.

**NB: Do not fully tighten screws until energy cells are fully loaded to ensure full weight is on feet and not on the wall fixings.**

**NOTE: UNDER NO CIRCUMSTANCES SHOULD ANY SCREWS BE REMOVED WITHOUT FIRST REMOVING ALL ENERGY CELLS FROM THE HEATER.**

**NEVER FREE THE HEATER FROM THE WALL WITH ENERGY CELLS REMAINING INSIDE THE HEATER CAVITY.**



**Fig. 6**

# Electrical Connections

**Warning:** Before obtaining access to terminals, all supply circuits must be disconnected.

7. The heater leaves the factory configured to operate with two mains supplies, a 24 hour peak supply and an off peak switched supply. (Fig. 7)

Not suitable for use on single supply.

## Storage / Fan circuit

Fan Circuit = PEAK L

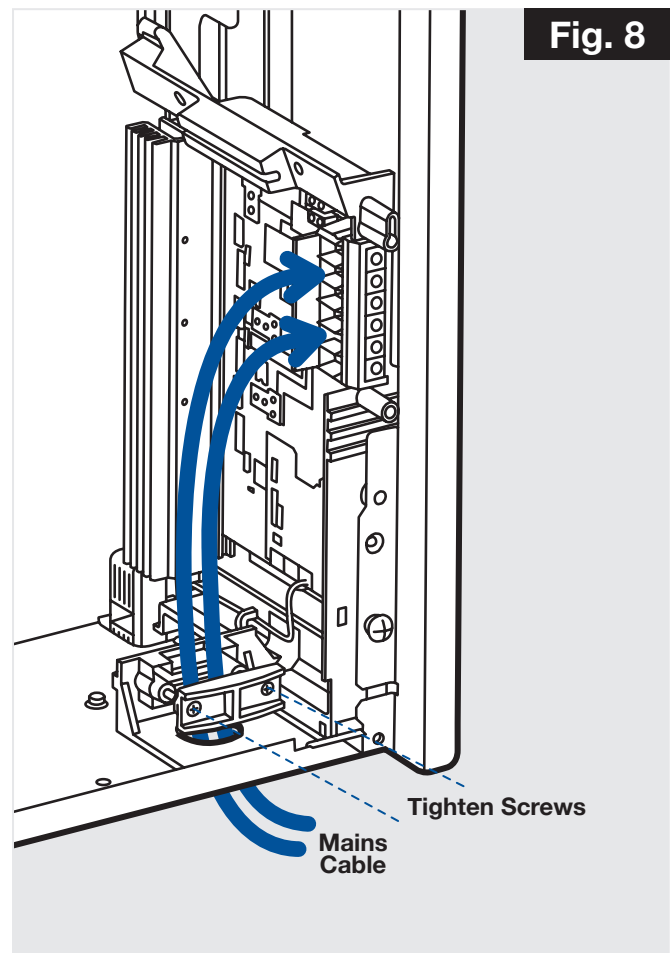
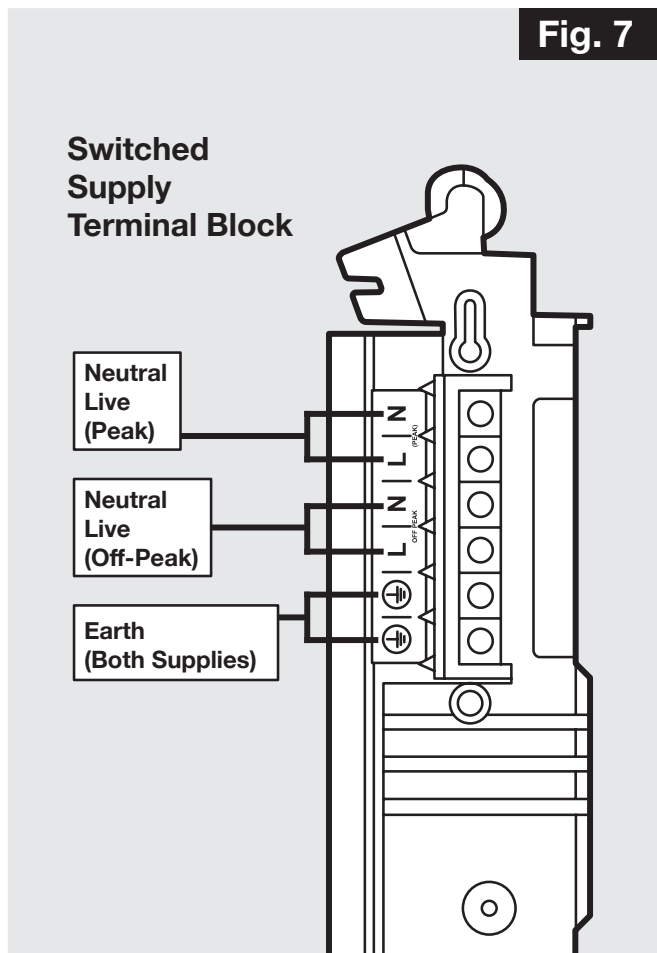
Storage Circuit = OFF-PEAK L

Fan Circuit = PEAK N

Storage Circuit = OFF-PEAK N

The earth wire should be connected into the earth terminal block marked E

**WARNING - Terminal block maximum torque 0.5 Nm**



**8.** The mains cable entry and terminal block will be visible on the right hand side of the unit. Insert the mains cables through the cable gland at the bottom of the heater in readiness for connection (**Fig. 8**).

**IMPORTANT** - Only heat resistant ordinary polyvinyl chloride sheathed flexible cord should be used, the following codes apply;

**IEC - 60227 IEC57** or **CENELEC - H05V2V2-F**

**Maximum Cable Sizes**

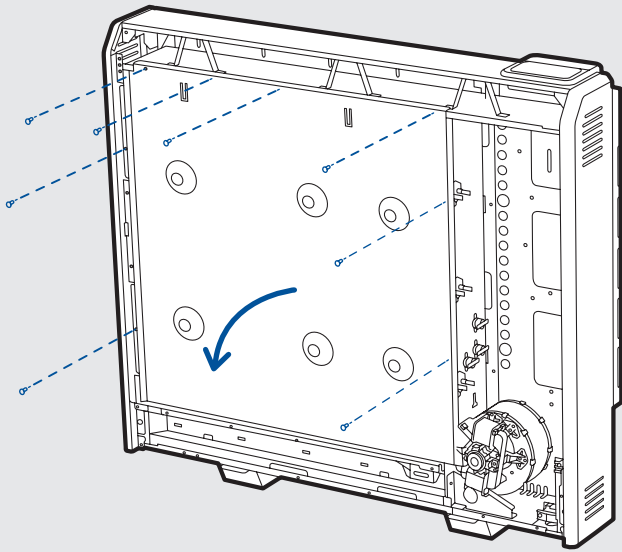
Peak mains cable 1.5mm<sup>2</sup>

Off-peak mains cable 2.5mm<sup>2</sup>

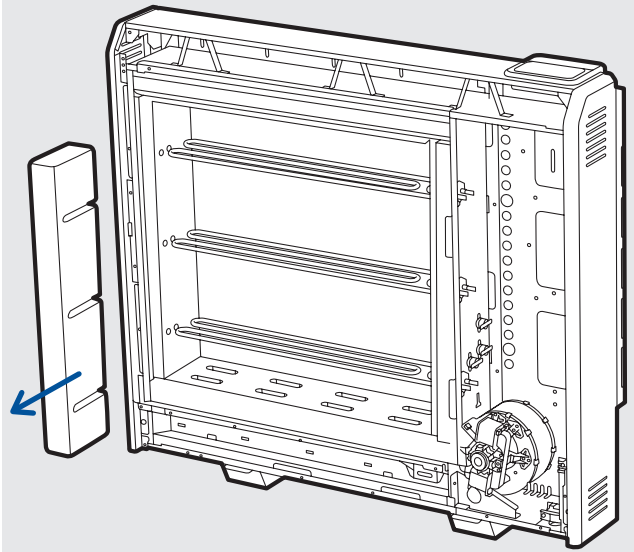
**WARNING - Maximum torque 0.5 Nm**

**WARNING:** All electrical connections to the terminal block must be secure to prevent risk of ignition.

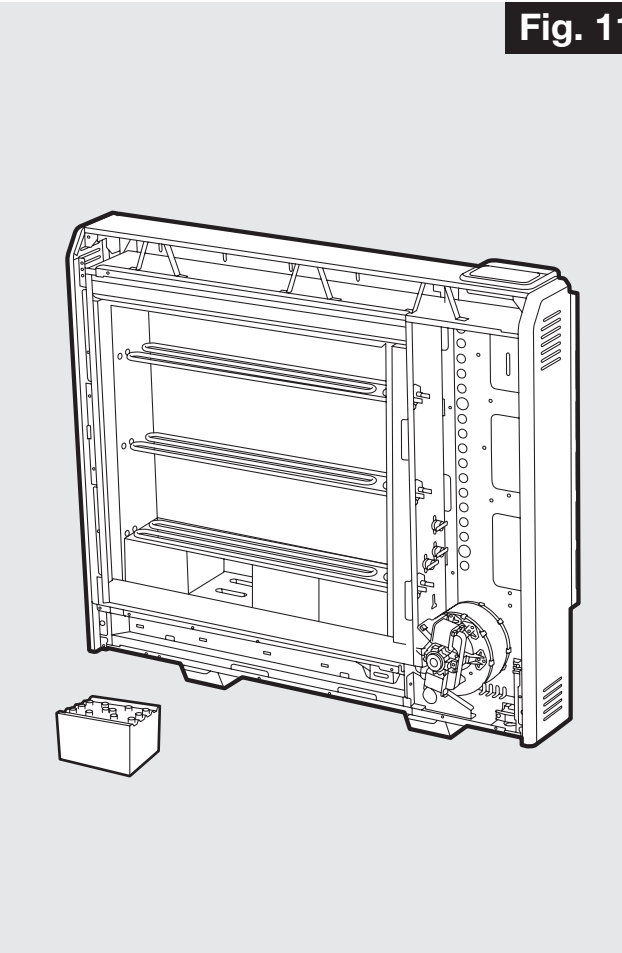
**Fig. 9**



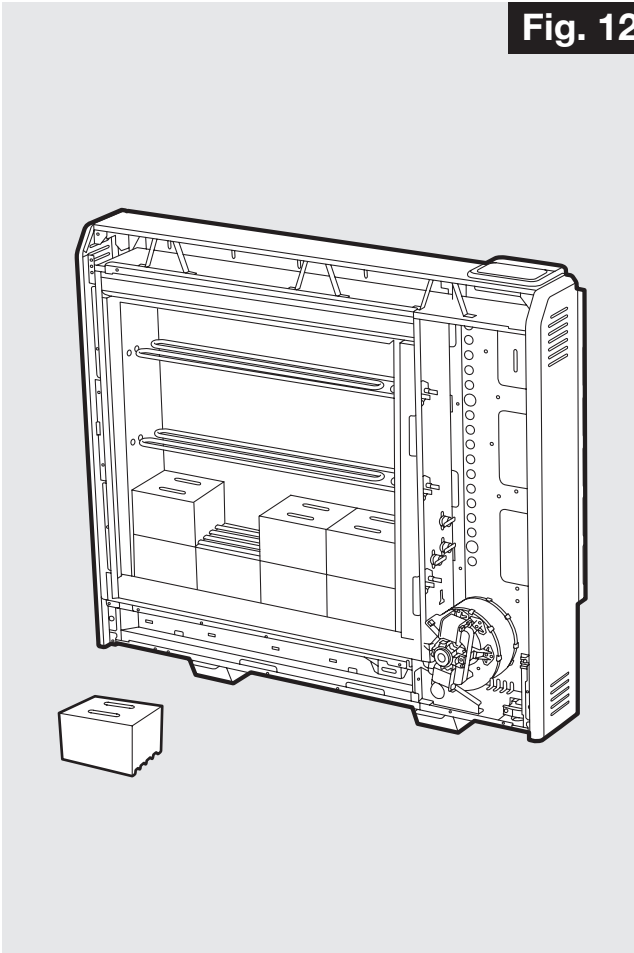
**Fig. 10**



**Fig. 11**



**Fig. 12**



## Building the Heater Core

9. Remove the inner front and insulation to gain access to the core of the heater. Lay the inner front carefully to one side to ensure it is not damaged. (Fig. 9)

10. Remove the cardboard element support and dispose of. (Fig. 10)

### Energy Cells

The energy cells are supplied separately to the heater in packs of three.



**Energy Cells should be handled with care due to the weight and risk of hand/foot injury.**

11. The energy cells have several grooves on one surface for locating around the elements. The two slots through the centre of the energy cell create the air passages within the core.

Position the first energy cell of the bottom row to the right, firmly pressed against the side insulation with the element grooves facing upwards and fitting neatly around the element. Angle the element upward to fit the energy cell.

Position the second energy cell in the row against the left-hand insulation. Place the remaining energy cells between the first and second in the row. (Fig. 11)

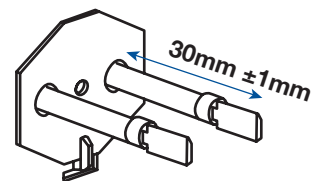
### DO NOT DISCONNECT THE ELEMENT TERMINALS

In addition ensure the slots for the air passages line up with the holes in the base insulation.



#### NOTE:

*The element tails must extend no further than 30mm into the right hand chamber.*

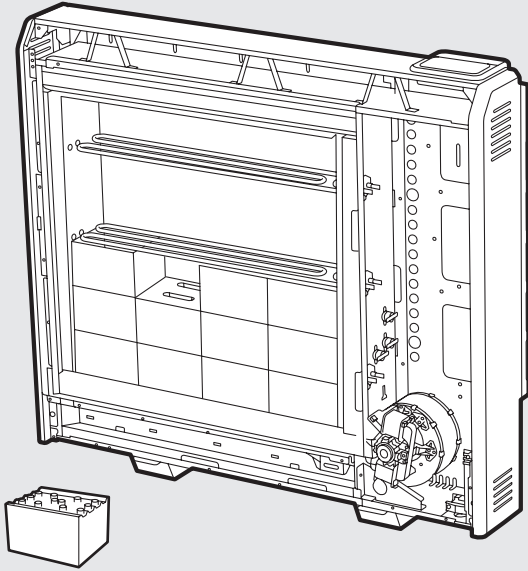


Fit the remaining energy cells to the bottom row, being careful not to damage or dislodge the element.

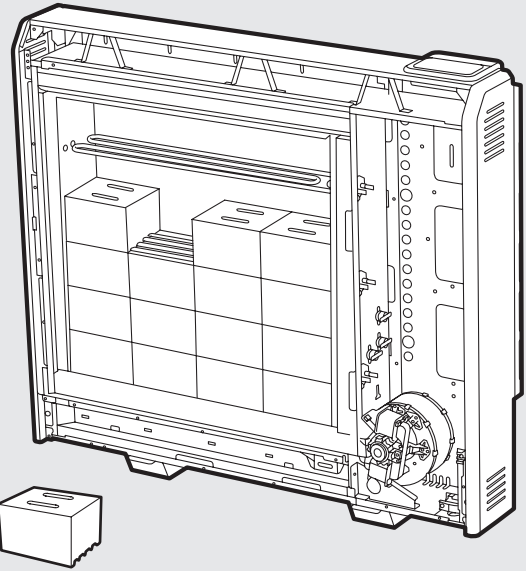
**Note - The bends in the element locate around the grooves in the energy cell to secure the element.**

12. Position the second row of energy cells on top of the first but this time the energy cells must be upside down ensuring the grooves are positioned over the elements. (Fig. 12)

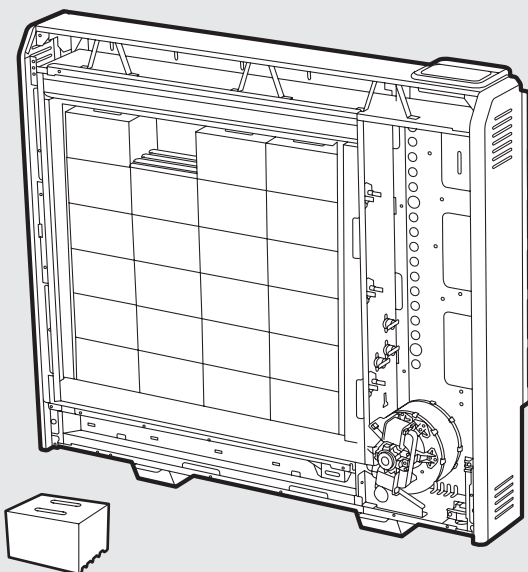
**Fig. 13**



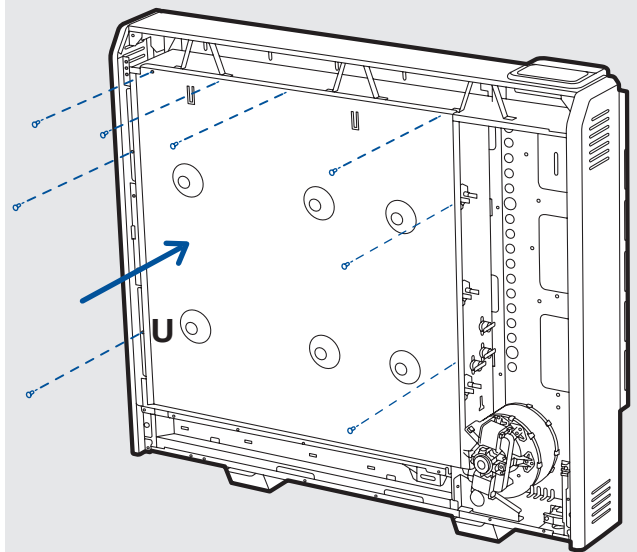
**Fig. 14**



**Fig. 15**



**Fig. 16**



**13.** The third row of energy cells is positioned in a manner similar to the first row. Again, be careful not to damage or dislodge the element. **(Fig. 13)**

**14.** Fit the fourth row of energy cells above the third row in the upside position. Again, the first energy cell should be positioned firmly against the right-hand insulation, and the second energy cell should be positioned firmly against the left-hand insulation. **(Fig. 14)**. Repeat for the fifth and sixth rows of energy cells built around the third element to complete the core build.

**15.** Remember the top row of energy cells must be fitted upside down. **(Fig. 15)**

Check that all the energy cells are secure and evenly located.

**16.** Close the core by refitting the inner front panel complete with insulation, starting at position 'U' and working clockwise. **(Fig. 16)**

Ensure the bottom tabs are located inside the chassis and that the screws are tightly secured down each edge.

Ensure the screws retaining the heater to the wall are fully tightened, once the energy retention cells are fully loaded. **(Fig. 6)**



## **IMPORTANT**

Double check all mains connections are secure and excess cable is restrained and not in contact with any of the heater casing.

**ON NO ACCOUNT SHOULD ANY SURPLUS CABLE BE PUSHED INSIDE OR BEHIND THE HEATER.**

**Once installed DO NOT attempt to reposition the heater without first unloading the energy cells.**

## **Reassembly**

To replace the bottom grille and front panel, reverse steps 3 and 4 of these instructions under the section headed **Preparation**.

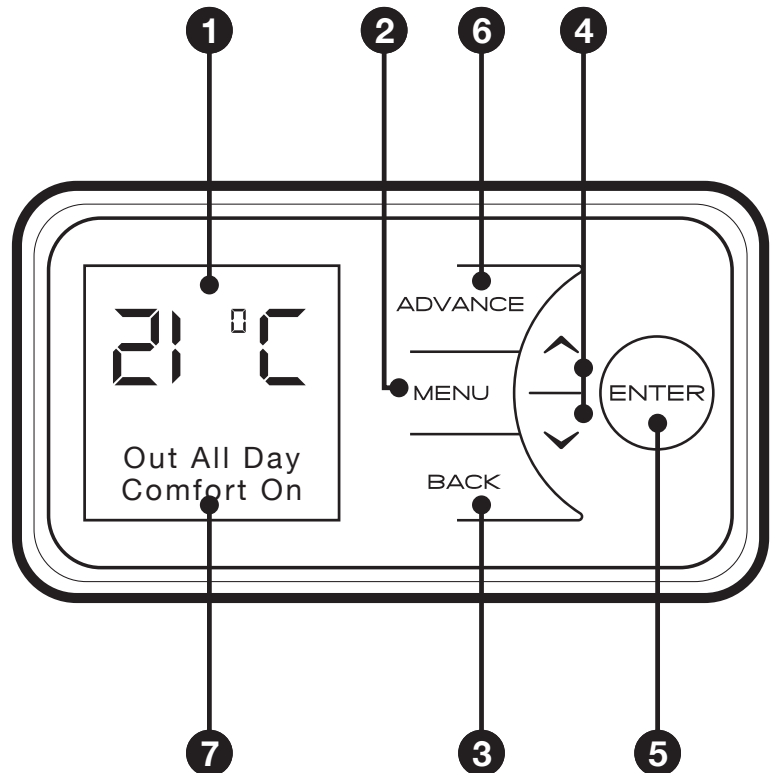
Inspect the grille guard for damage before refitting the lower grille to the heater.

Ensure all fixings are secure.

## Operation

The controls are located on the top of the heater. The heater is fitted with an adjustable electronic controller consisting of a display screen and six touch sensitive buttons.

- ❶ Display Screen
- ❷ 'Menu' Button
- ❸ 'Back' Button
- ❹ 'Up and Down' Arrows
- ❺ 'Enter' Button
- ❻ 'Advance' Button
- ❼ Heating Status



The heater is fitted with an adjustable thermostat enabling the room temperature to be controlled. The **minimum** room temperature is 7°C. The **maximum** temperature is set to 26°C. A temperature of 21°C represents a **normal** room temperature.



### NOTE:

Your heater may produce some noise during operation. This noise is caused by the low noise fan and expansion and contraction of the metalwork as it changes temperature, and is normal for this type of product. Whilst the noise produced is usually very quiet, certain environmental factors can make it more noticeable, such as hard flooring or minimal furnishings.



### NOTE:

Should the heater fail to operate, this may be due to the room temperature being higher than the thermostat setting.



# Control Functions

The heater controls can be easily adjusted by using the six buttons on the User Interface.

- ① The **Display Screen** shows the options available at each stage of adjustment.
- ② **Menu** - displays the main options list;
  - **Date/Time** - Set the date and time.
  - **Mode** - Set the mode of operation.
  - **Options** - Keypad sound, daylight savings time, communication settings and service information.
- ③ **Back** returns to the previous programming stage.
- ④ The **UP** and **DOWN** buttons are used to navigate through the menus and alter setting values. The **UP** and **DOWN** buttons are also used to adjust the required room temperature on the main screen. The screen colour changes based on the temperature selected, showing deep blue through to bright red.
- ⑤ **Enter** is used within the menu options to confirm settings. On the main screen pressing **Enter** will display the enabled features.

The timed periods during which the heater is providing heat are defined as '**Comfort On**' (this is displayed at the bottom of the screen).

Outside of heating periods the heater will not deliver heat and these periods are called '**Comfort Off**'.

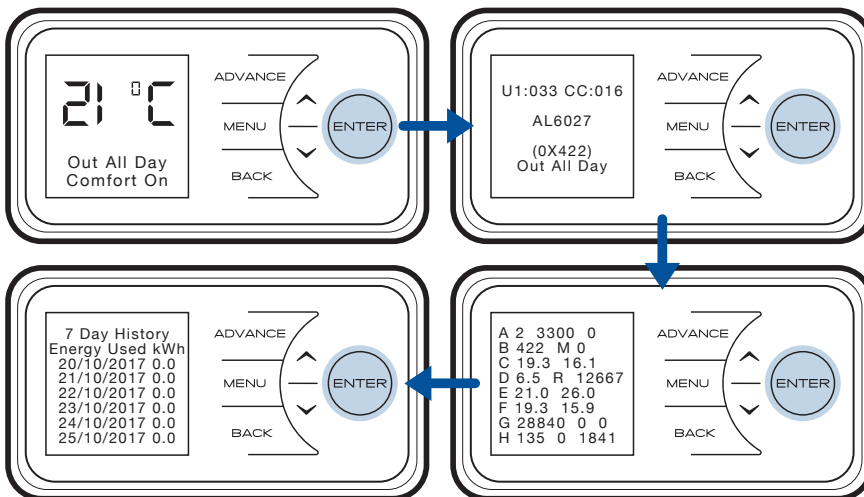
While constant heat modes are active, the mode of operation is displayed at the bottom of the screen e.g. '**Out All Day**'.

- ⑥ The **Advance** button overrides the heating settings and changes the operational state of the heater. Pressing **Advance** will cause the heater to remain on until the next **Comfort Off** period is due, or off until the next **Comfort On** period is due.

## Main Screen

After 30 seconds the heater will default back to the **Main Screen**. Here the chosen temperature is displayed along with the mode of operation. Any use of the **Advance**, **Boost**, function will be displayed here, and pressing **Enter** will show engineer's diagnostics and 7 day history screens.

When left inactive for a long period of time this display will 'sleep' and the text will disappear. Press any button for its return.



**NOTE:**  
The display screen will return to the main screen after a period of 30 seconds of inactivity.

**NOTE:**  
Pressing enter will show the engineer's diagnostics and 7 day history screens. Ref: page 17.

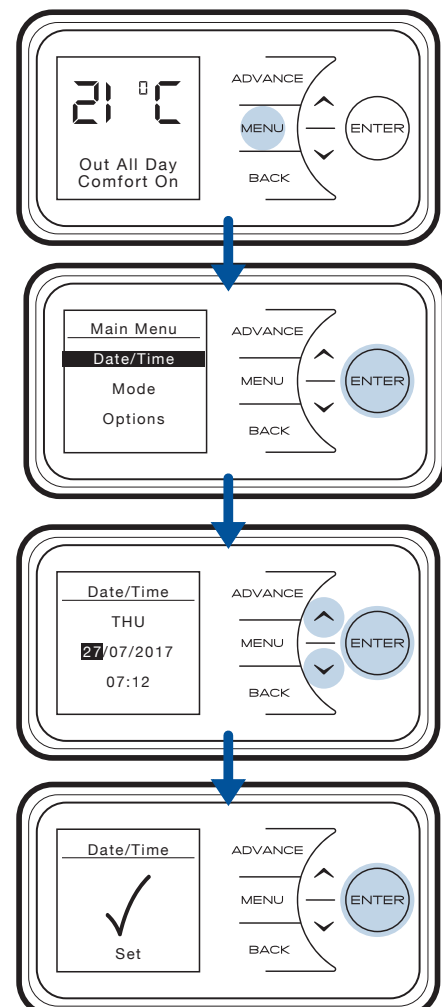
## Setting the Date and Time

The heater incorporates a real time clock with calendar function. The time clock has a battery backup that will keep the clock running in the event of a mains power outage.

To adjust the time or date follow the steps below.

Press the **Menu** button. Select **Date/Time** by pressing the **Enter** button. Press **UP** and **Down** to select the correct day of the month and press **Enter** to select.

Repeat this operation, until the date and time has been set, ensuring to press **Enter** to select. Press **Back** button to return to the **Main Screen** once **Set** has been displayed.



## Mode of Operation

The heater comes pre-programmed with a set of heating profiles. There are three options available - two pre-programmed and one user adjustable timer;

1. **User Timer** (pre-programmed, factory default) - provides greatest flexibility to the user. Four time slots are available throughout the day and these can be customised for each day of the week. Factory default times: 06.30 until 09.30, 11.00 until 13.00, 15.00 until 17.00, 18.00 until 22.00.
2. **Out All Day** (pre-programmed) - has the following preset times Monday to Sunday, which can be altered if desired 07.00 until 08.30 17.30 until 22.00, (factory default times).
3. **Holiday** - set the date of return and the temperature required. 7°C is advised if you just want to protect the property from frost while you are away.

The heater can also maintain a constant room temperature using the following modes;

1. **Boost** mode heats the room to a selected temperature for 1, 2 or 3 hours..
2. **Auto Boost Function** maintains a room temperature during comfort periods, when the core is depleted.



**NOTE:**

*In all modes, except holiday mode, **Up** and **Down** can be used to adjust the required room temperature.*



**NOTE:**

*It is recommended that the timer is used as doing so can reduce the running cost. Operating the appliance in the permanent heating modes as **Boost** or **Auto Boost** may result in increased running costs.*

# Choosing and setting a Mode

## Timer Modes

To choose a timer mode press **Menu** and then **Down** to select **Mode**. Then press **Enter**. Then select **Timer Mode**, again using the **Enter** button.

Select the mode required, by pressing the **Up** or **Down** followed by **Enter**.

For options **Out All Day**, and **User Timer**, three choices are available - **Select**, **Preview** and **Modify**.

- **Select** - choose this timer option.
- **Preview** - view the times currently set.
- **Modify** - change the times currently set.

When **Modify** is chosen, select and change each option using the **Up**, **Down** and **Enter** buttons. At the end of each period, select **Next** to move to the following period. When a day is complete select **Save** to update it.

Once the first day has been set up it is possible to copy these settings to successive days or all days by either choosing **Copy Next** or **Copy All**.

If preferred each day can be modified individually and saved. It is also possible to **Clear** each day or **Clear All** days to factory default times. Options are;

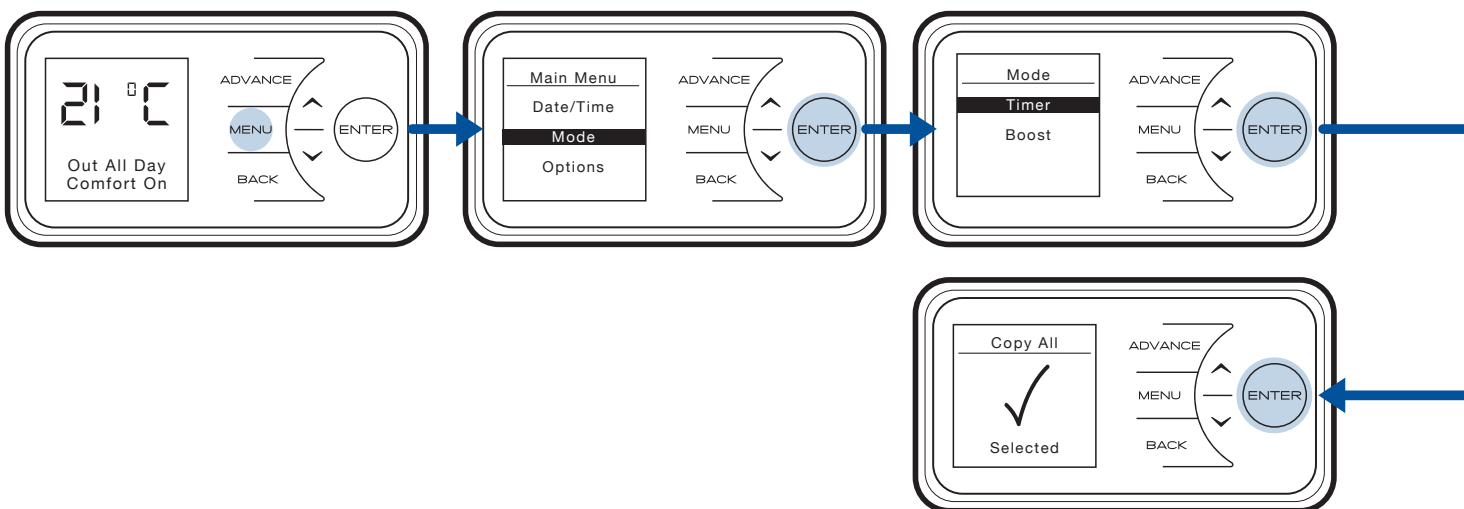
- **Save** - save times for one day.
- **Copy Next** - copy times to following day.
- **Copy All** - copy times to all seven days.
- **Clear** - factory defaults all times that day.
- **Clear All** - factory default times for all seven days.



### NOTE:

Once modified a programme must be selected if you want to begin using it.

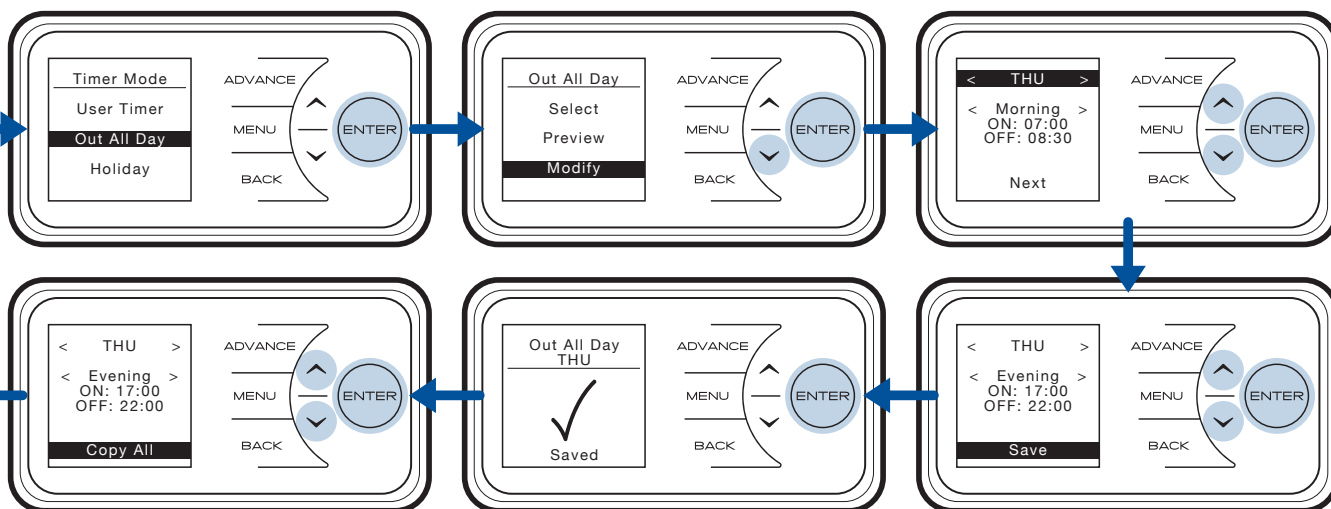
To select a mode, choose **Select** and press **Enter**.



In **Holiday** mode the date until the room will be unoccupied can be set/adjusted together with the required room temperature.

Press **Up** and **Down** to set the return date, then press the **Enter** button.

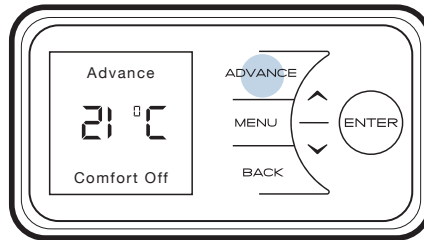
Press **Up** and **Down** to choose a temperature to be maintained during this period and press the **Enter** button. At the end of the holiday mode the heater will automatically revert back to the previously selected programme.



## Advance

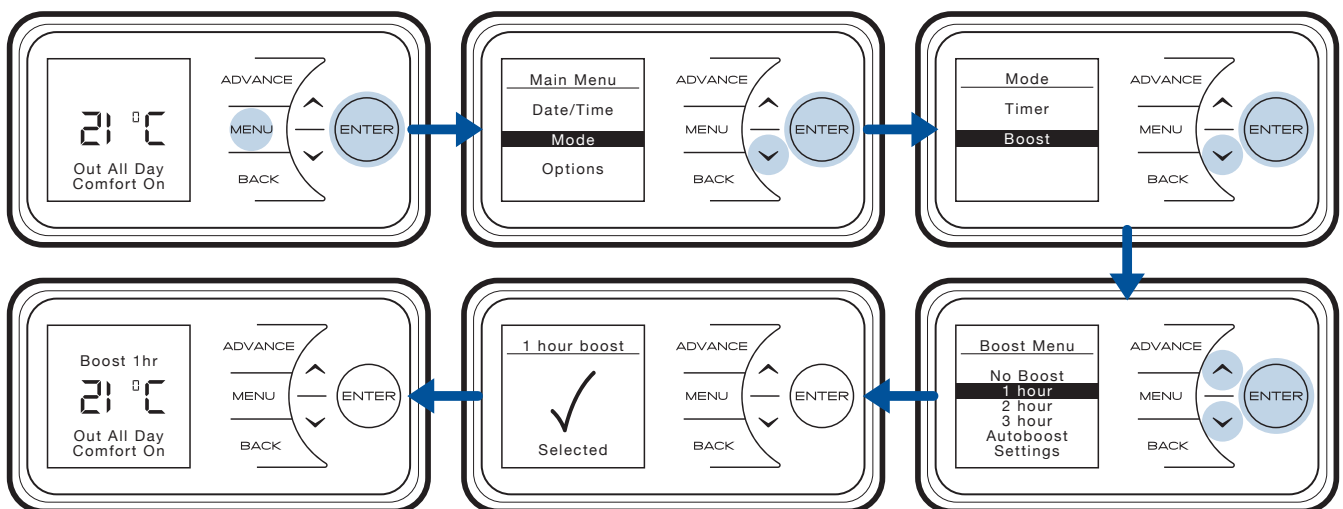
The **Advance** function allows the heating profile of the heater to be changed temporarily. When a timer has been selected, the **Advance** function is used to begin the next **Comfort On** mode early. If the heater is in **Comfort Off** mode and heat is required, press the **Advance** button.

If the heater is in **Comfort On** and heat is not required, press the **Advance** button and the heater will turn off until the beginning of the next **Comfort On** period.



## Boost

**Boost** mode provides temporary heating for one, two or three hours. **Auto Boost** maintains a room temperature during **Comfort On** periods, when the core is depleted.



## Options

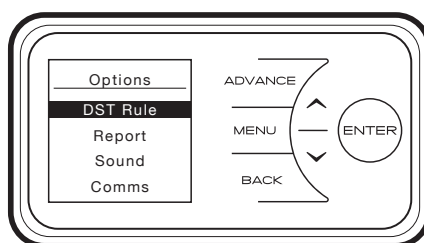
The **Options** menu allows the settings to be modified to suit the user's preferences. These are;

**DST Rule** - Select your daylight saving setting. The heater clock will automatically adjust for daylight saving (British Summer Time as it is often referred to). If no adjustment is required then select none.

**Report** - Service information is displayed.

**Sound** - Audio feedback can be enabled or disabled.

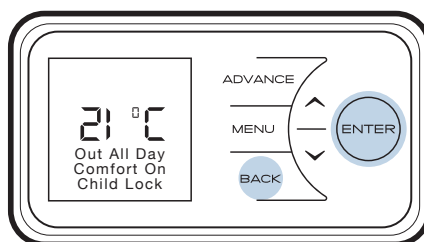
**Comms** - Choose to enable or disable **Wireless Connectivity**. If additional **RF Module** is connected, user will have option to enable or disable RF communications.



## Child Lock

In cases where unauthorised persons may tamper with the control settings it is possible to set a tamper-proof feature.

To lock the controls press **Back** and **Enter** for three seconds. **Child Lock** will appear at the bottom of the screen. To unlock the control repeat the action of pressing **Back** and **Enter** for three seconds.



**NOTE:**  
The controls cannot be adjusted when child lock is active.

# User Information

## User Information

Press and hold **Enter** for five seconds to enter the **User Information** menu;

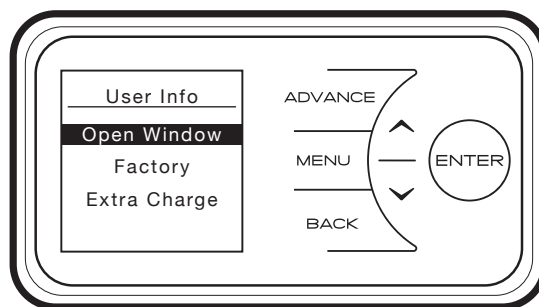
**Open Window detection** (OW), when enabled, the heater will reduce the target room temperature to limit the energy waste when an open window is detected. Disabled as default.

**Factory Reset** returns all settings to the factory presets.

**Extra Charge** - forces an extra charge of up to seven hours during off-peak periods.

If the output of the heater is not able to deliver the required comfort level, then it is possible to force the heater to store additional energy. In this way, more electrical energy is stored during the off-peak period and this will increase comfort levels. Up to seven hours additional off-peak charging can be selected.

**Note: The extra charge option will lead to more energy being stored during the off peak period, this will lead to higher running costs. Only use this setting when a room is consistently below the required temperature and you are sure that the timer mode is set up and selected correctly.**





## Service

In order to enter the Service menu, Back, Menu & Enter must be pressed simultaneously and held for 10 seconds.

**Charge Time** - for Service personnel use only.

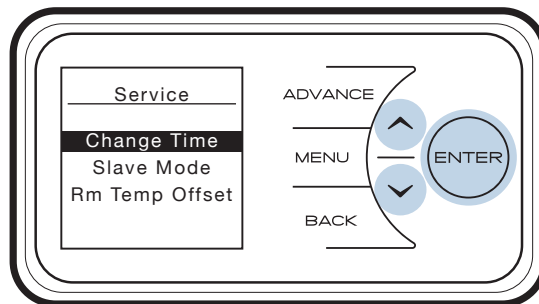
**Slave Mode** - for Service personnel use only.

If more than one heater is installed in the same room it is recommended that the smallest capacity heater is set as a Slave.

Disabled as factory default.

**Rm Temp Offset** - for Service personnel use only.

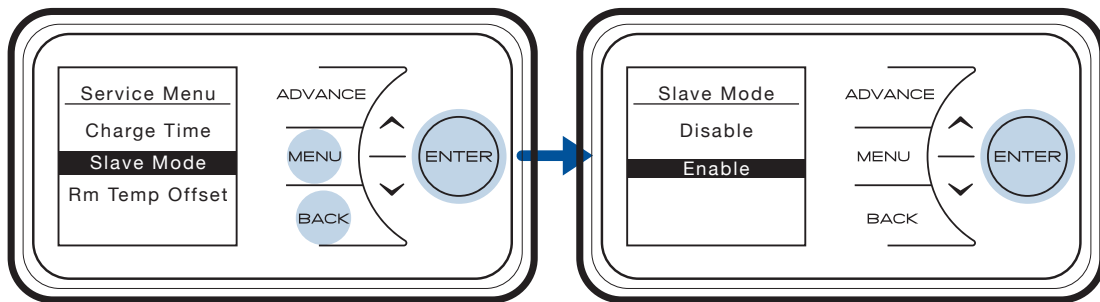
Allows to set a Room Sensor temperature offset.  
Factory pre-set offset as default.



## Slave Mode

If more than one heater is installed in the same room it is recommended that the largest capacity heater is set as the master and all smaller capacity products are set as slaves.

Press **Menu**, **Back** and **Enter** for 3 seconds to enter the service menu, select '**Slave Mode**' and press **Enter**. Select '**Enable**'.



This page is deliberately left blank.

## Energy Saving Tips

The energy we use to heat, light and power our homes contributes over a quarter of the UK's carbon emissions, the principle contributor to climate change. Around half the energy used in the home is for heating and hot water, so using your heating system efficiently will not only help the environment, but also save you money.

### Energy efficiency tips for heating and hot water

- 1. Don't set the temperature to high...**  
By reducing the thermostat setting by just 1°C, you can reduce your energy use by as much as 10%. And if you're going away during the winter, leave the thermostat on the **Holiday** setting to provide protection from freezing at a minimum cost.
- 2. Use it where you need it...**  
Set the appropriate temperature on your heaters for the room they are in; for example, leave the thermostat on a heater in a spare bedroom on a lower setting.
- 3. Use it when you need it...**  
Use heaters fitted with timers or linked to central controllers to turn the heating on only when you need it and automatically switch it off when you don't.
- 4. Curtains**  
Close your curtains at dusk to stop heat escaping through the windows.
- 5. Windows**  
Nearly 25% of heat loss can occur through poorly insulated frames and single glazing. If you can't afford to double glaze all your windows, go for the rooms you heat most.
- 6. Treat your hot water tank...**  
Give it a jacket. An insulating jacket for hot water tanks costs only a few pounds and pays for itself within months. Fit one that's at least 75mm (3") thick and you could save £10-15 a year.
- 7. Water**  
Use a shower if you have one to save time, money and water. Don't set the thermostat too high on your water heater - 60°C/ 140°F is usually adequate for bathing and washing. Put the plug in when running hot water in your sink - leaving hot taps running is both wasteful and expensive. Ensure dripping taps are repaired quickly. In just one day, you could waste enough water to fill a bath.

### Other Energy Saving Tips for Around the Home

- 1. Lights**  
Turn off lights whenever you leave a room for more than ten minutes. Use low-energy bulbs wherever you can as they use less than a quarter of the electricity used by ordinary light bulbs and last ten times longer!
- 2. Cooking**  
Use the right size pan for food and cooker hob. Keep saucepan lids on - this enables you turn down the heat. Boil water for cooking in a kettle first.

## Important

During the initial operation, some odour may be noticed due to the newness of materials used in manufacture. This is normal and will disappear after a short period of use. It is however advisable to keep the room well ventilated.

### Cleaning

**WARNING - ALWAYS ISOLATE THE POWER SUPPLY BEFORE CLEANING THE HEATER.**

Before commencing cleaning allow the heater to cool. The outside can be cleaned by wiping it over with a soft damp cloth and then dried. Do not use abrasive cleaning powders or furniture polish, as this can damage the surface finish.

Discolouration of wall finishes can sometimes occur immediately above a heater due to the properties of some paints and decorating materials or the presence of environmental impurities in the air (such as soot, cigarette smoke or incense generated from the burning of candles, etc.). A suitable shelf may be fitted to limit the extent of any wall discolouration.

## Important

### Recycling



For electrical products sold within the European Community. At the end of the electrical products useful life it should not be disposed of with household waste. Please recycle where facilities exist. Check with a Local Authority or retailer for recycling advice in your country. Batteries should be disposed of or recycled in accordance with WEEE Directive 2012/19/EU. Packaging should be recycled where possible.

## Important



For electrical products sold within the European Community. At the end of the electrical products useful life it should not be disposed of with household waste. Please recycle where facilities exist. Check with a Local Authority or retailer for recycling advice in your country. Batteries should be disposed of or recycled in accordance with WEEE Directive 2012/19/EU. Packaging should be recycled where possible.

### **What does a Creda Guarantee cover?**

Creda products deliver reliable service for normal, household use in domestic settings. All Creda products are individually tested before leaving the factory.

If you are a consumer and you experience a problem with your Creda product, which is found to be defective due to faulty materials or workmanship within the Guarantee Period, this Creda Guarantee will cover repair or - at the discretion of Creda - replacement with a functionally equivalent Creda product.

The Creda Guarantee Period is two calendar years from the date of purchase of your Creda product, or the date of delivery of the product, if later. The Creda Guarantee is conditional upon you providing the original purchase receipt as proof of purchase. Please therefore retain your receipt as proof of purchase.

If you do experience a problem with your Creda product please call the Helpline on 0344 879 35 88 or visit <http://www.credaheating.co.uk/contact> and complete the online form. For ROI please email [serviceireland@glendimplex.com](mailto:serviceireland@glendimplex.com) or call +353(0)1 842 833. We will need details of your Creda product, its serial number and a description of the fault which has occurred. You can find the model number and serial number for your Creda product on the heaters side. Once we receive your information and proof of purchase we will contact you to make the necessary arrangements.

If your Creda product is not covered by this Creda Guarantee there may be a charge to repair your product. However, we will contact you for agreement to any charges before any chargeable service is carried out.

### **What is not covered by a Creda Guarantee?**

The Creda Guarantee does not cover any of the following:

- Any fault or damage to your Creda product due to faulty materials or workmanship occurring outside the two-year Guarantee Period.
- Any fault or damage occurring to any pre-owned Creda product or to any other equipment or property.
- Accidental damage to your Creda product or damage to your Creda product from external sources (for example, transit, weather, electrical outages or power surges).
- Fault or damage to your Creda product which is:
  - Not due to faulty materials or workmanship or which is due to circumstances outside Creda's control.
  - Caused by use of your Creda product for anything other than normal domestic household purposes in the country where it was purchased.

## **Important**

- Caused by any misuse, abuse or negligent use of the Creda product, including but not limited to any failure to use it in accordance with the Operating Instructions supplied with the product.
- Caused by any failure to assemble, install clean and maintain your Creda product in accordance with the Operating Instructions supplied with the product unless this was carried out by Creda or its authorised dealers.
- Caused by repairs or alterations to your Creda product not carried out by Creda service personnel or its authorised dealer(s).
- Caused by use of any consumables or spare parts for your Creda product which are not Creda -specified.

## **Terms and Conditions**

- The Creda Guarantee is valid for Creda from the date of purchase of your Creda product from a recognised retailer in the country of purchase and use, or the date of delivery of the product if later, always provided the original receipt has been retained and is produced as proof of purchase.
- You must provide to Creda or its authorised agents on request the original receipt as proof of purchase and - if required by Creda - proof of delivery. If you are unable to provide this documentation, you will be required to pay for any repair work required.
- Any repair work under the Creda Guarantee will be carried out by Creda or its authorised dealer(s) and any parts that are replaced will become the property of Creda. Any repairs performed under the Creda Guarantee will not extend the Guarantee Period.
- Any replacement of your Creda product by Creda during the Guarantee Period will start the two-year Guarantee Period afresh from the date of delivery of the replacement Creda product to you.
- The Creda Guarantee does not entitle you to recovery of any indirect or consequential loss or damage including but not limited to loss or damage to any other property.
- The Creda Guarantee is in addition to your statutory rights as a consumer and your statutory rights are not affected by this Creda Guarantee.

## **Contact Creda**

If you have any questions about what the Creda Guarantee covers and does not cover or how to claim under the Creda Guarantee, please contact us using the information on the back page.

## **Contact details**

Glen Dimplex Heating & Ventilation, Milbrook House, Grange Drive, Hedge End, Southampton,

## Battery Replacement

Fig. 17

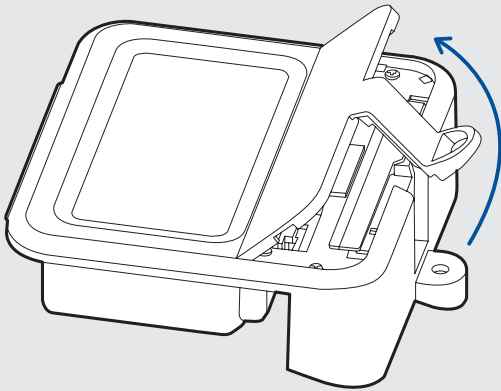


Fig. 18

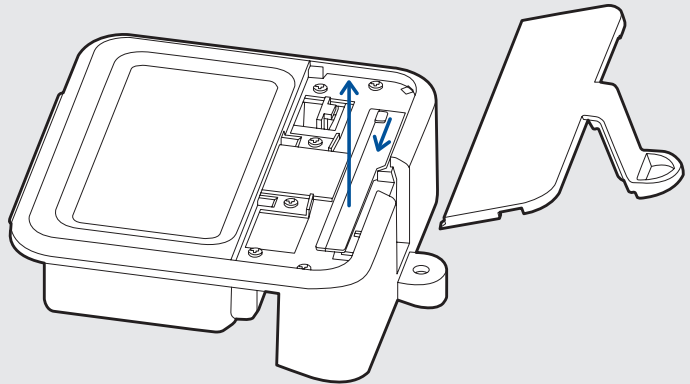


Fig. 19

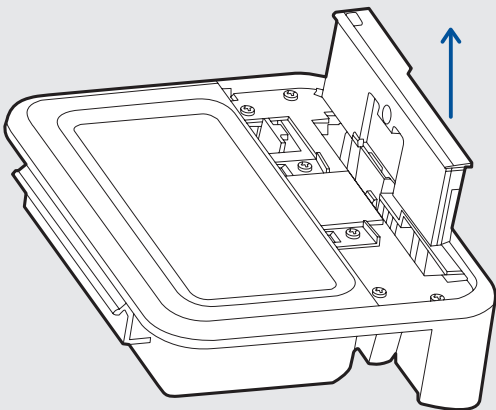
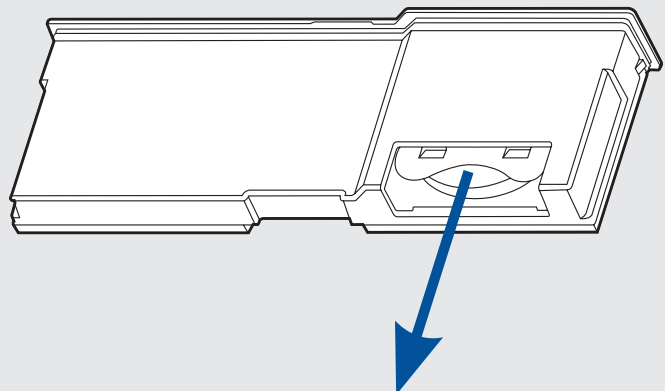


Fig. 20



**IMPORTANT:** Before replacing the battery ensure the heater is isolated from the electricity supply.

NOTE – Battery should be disposed of in an appropriate manner

This product is fitted with a replaceable battery in the controls. To replace the battery, follow the steps below.

1. Unscrew the cover of the user interface and pivot away from the housing as shown in **Fig. 17**. Set the cover and the screw safely to one side.
2. Slide the catch and pull the module up from the User Interface as shown in **Fig. 18**
3. Move the module clear of the User Interface to access the battery, **Fig. 19**
4. Remove the coin cell battery and replace.
5. Slide the module back into the User Interface, ensuring the catch is engaged
6. Replace the cover and secure using the screw

**Clean the outlet grilles and adjacent surfaces after the first operation as some dust may be produced when the heater is first used.**



## Energy Related Product Directive

This product complies with Lot20 of the Energy Efficiency Directive (2015/1188).

Model Identifier(s):		TSRE050	TSRE070	TSRE100	TSRE125	TSRE150	Unit
<b>Heat output</b>							
Nominal heat output	P <sub>nom</sub>	0.5	0.75	1.0	1.25	1.5	kW
Minimum heat output (indicative)	P <sub>min</sub>	0.0	0.0	0.0	0.0	0.0	kW
Maximum continuous heat output	P <sub>max,c</sub>	0.8	1.0	1.2	1.4	1.6	kW

### Type of heat input for electric storage local space heaters

Electronic heat charge control with room temperature feedback Yes

### Type of heat output / room temperature control

Electronic room temperature control plus 7 day timer Yes

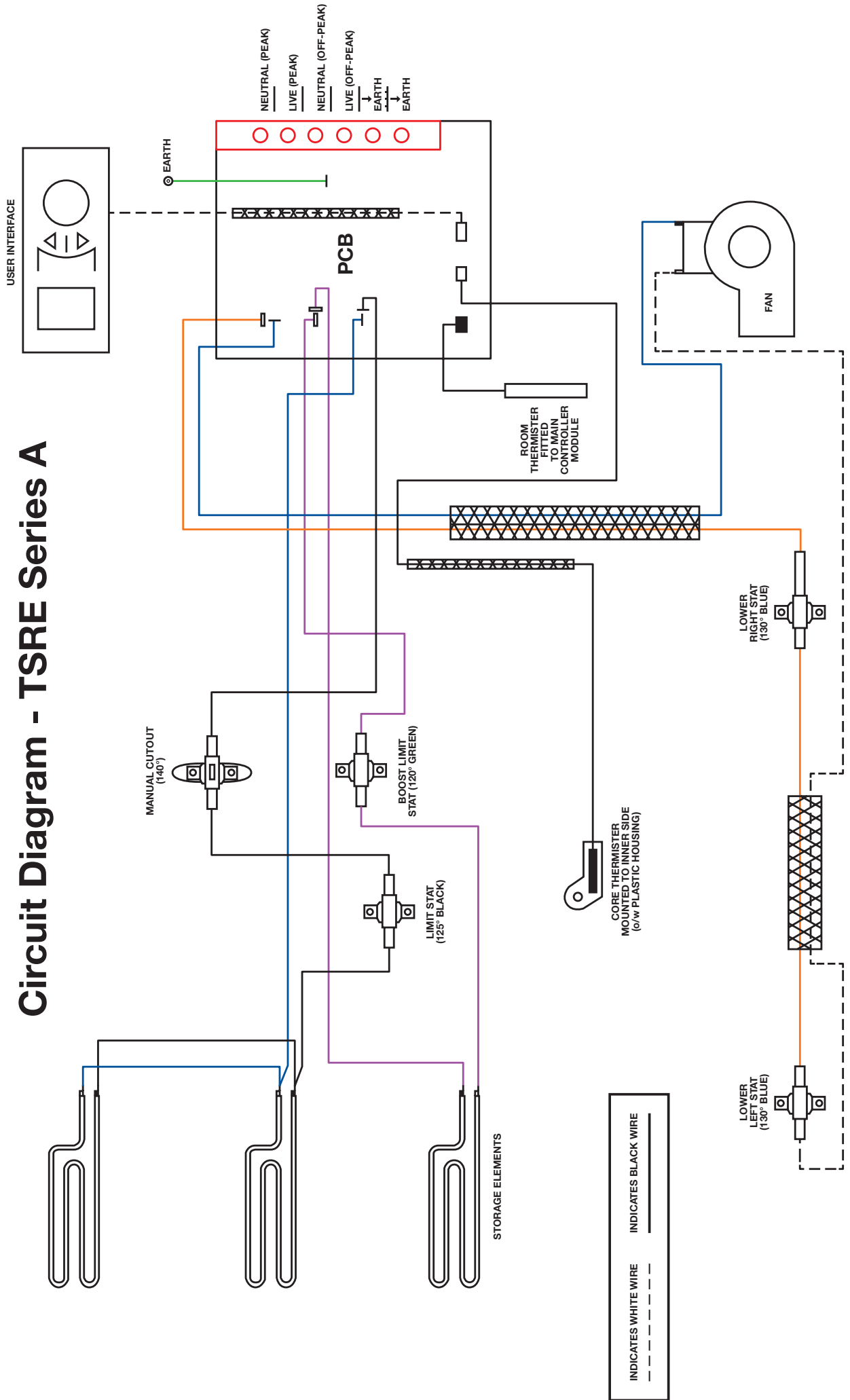
### Contact details

Glen Dimplex Heating & Ventilation  
Millbrook House, Grange Drive, Hedge End, Southampton, SO30 2DF

Tel: 0344 879 35 88

This product complies with Lot20 of the Energy Efficiency Directive (2015/1188).

# Circuit Diagram - TSRE Series A





---

**Creda**  
HEATING

**Customer Helpline:** 0344 879 35 88  
aftersales@credaheating.co.uk  
www.credaheating.co.uk

Glen Dimplex Heating & Ventilation.  
Millbrook House, Grange Drive, Hedge End, Southampton, SO30 2DF

---

© Glen Dimplex. All rights reserved. Material contained in this publication may not be reproduced in whole or in part, without prior permission in writing of Glen Dimplex

**CE** This product complies with the European Safety Standards EN60335-2-30 and the European Standard Electromagnetic Compatibility (EMC) EN55014, EN61000-3-2 and EN61000-3-3. These cover the essential requirements of EEC Directives 2006/95/EC and 2004/108/EC